

51620000 51625000 51626000

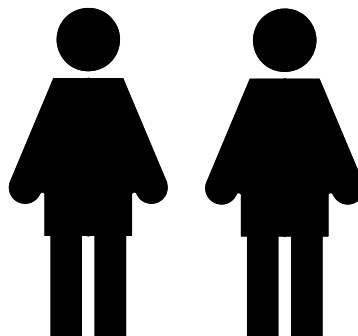
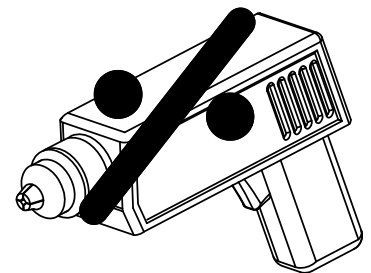
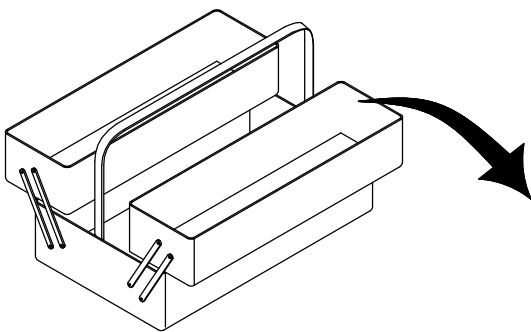
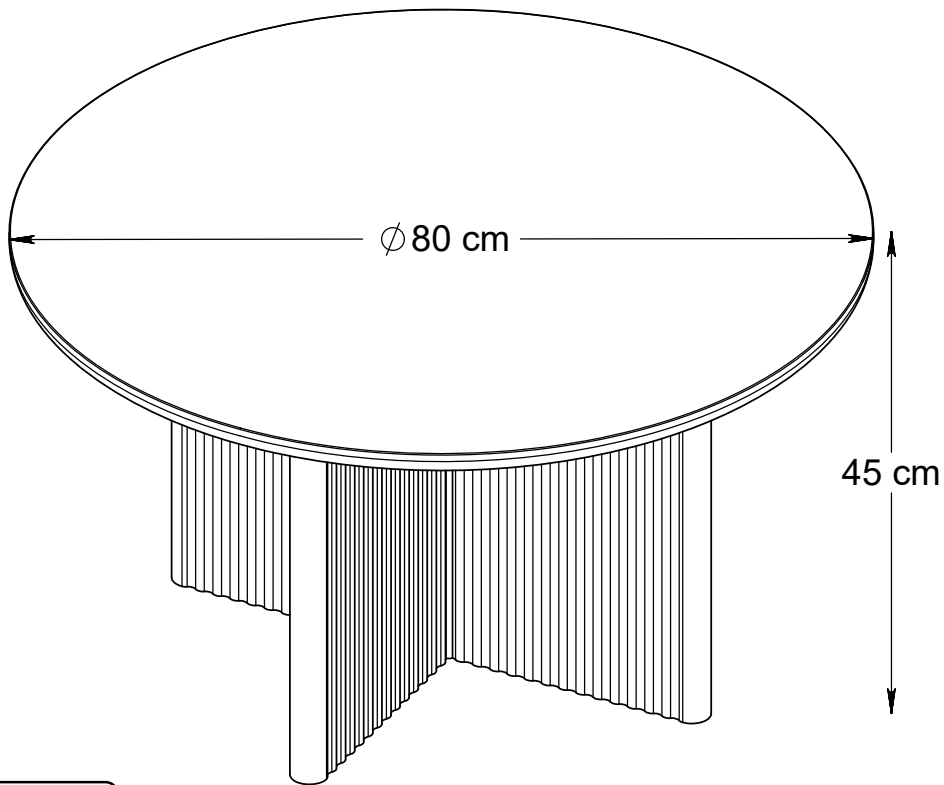

WICHTIG - FÜR SPÄTERE VERWENDUNG
AUFBEWAHREN - SORGFÄLTIG LESEN

AVIS - Ces instructions doivent être sauvegardées
Pour utilisation future - Les instructions doivent
être suivies

IMPORTANTE, conservar estas instrucciones
para futuro uso. Siga estas instrucciones atentamente

VIGTIGT - Samvejledningen skal opbevares
i arkiv til senere brug - Skal gennemlæses nøje

NOTICE - These instructions must be saved
for future use - Instructions must be followed

51620000

TEILCHECKLISTE
LISTE DE CONTROLE
LISTADO DE CONTROL
TJEKLISTE
CHECK LIST

| Réf./No. | Réf./Art. | Qty./Stck./Quantité | Size / Maß / Dimension (mm) | Packed in box | ✓ |
|----------|-----------|---------------------|-----------------------------|---------------|---|
| 1 | 33115900 | 1 | Ø800x25 | 1 | |
| 2 | 33116000 | 1 | 560x422x37.5 | 1 | |
| 3 | 33116100 | 1 | 560x422x37.5 | 1 | |
| | | | | | |

51625000

| Réf./No. | Réf./Art. | Qty./Stck./Quantité | Size / Maß / Dimension (mm) | Packed in box | ✓ |
|----------|-----------|---------------------|-----------------------------|---------------|---|
| 1 | 33115950 | 1 | Ø800x25 | 1 | |
| 2 | 33116050 | 1 | 560x422x37.5 | 1 | |
| 3 | 33116150 | 1 | 560x422x37.5 | 1 | |
| | | | | | |

51626000

| Réf./No. | Réf./Art. | Qty./Stck./Quantité | Size / Maß / Dimension (mm) | Packed in box | ✓ |
|----------|-----------|---------------------|-----------------------------|---------------|---|
| 1 | 33115960 | 1 | Ø800x25 | 1 | |
| 2 | 33116060 | 1 | 560x422x37.5 | 1 | |
| 3 | 33116160 | 1 | 560x422x37.5 | 1 | |
| | | | | | |

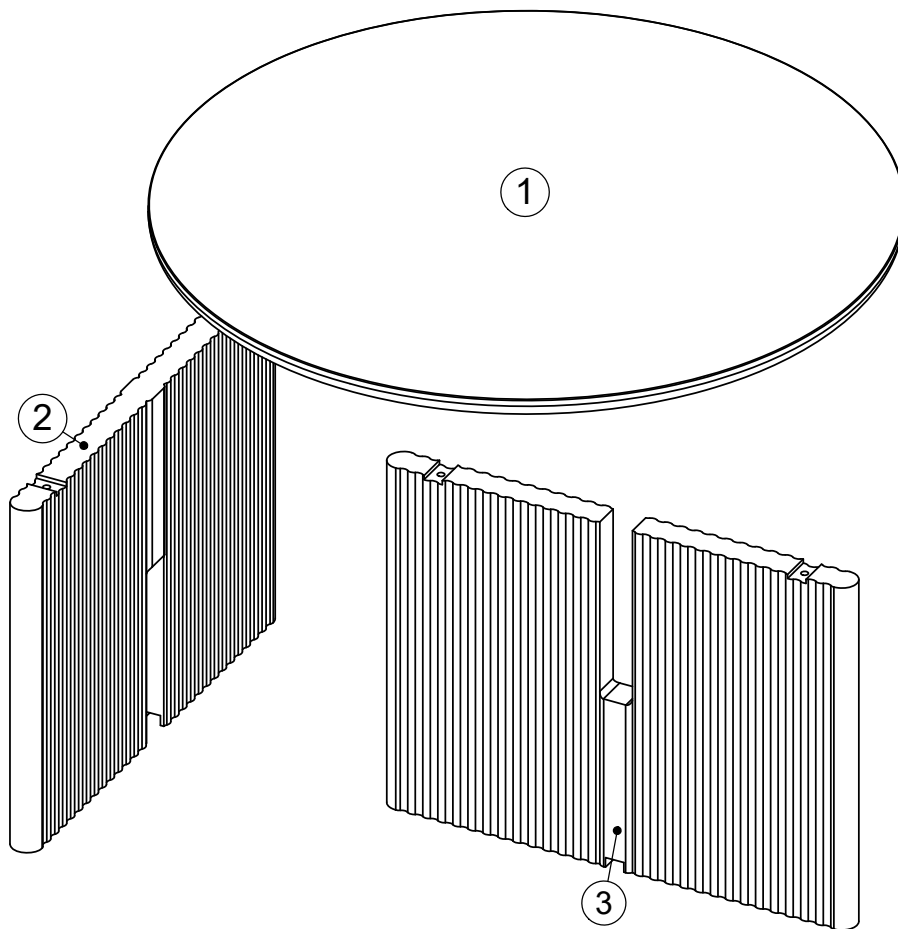





51620000

| Réf./No. | Réf./Art. | Qty./Stck./Quantité | ✓ |
|----------|-----------|---------------------|---|
| A | 233649 | 15 | |
| B | 233649 | 4 | |
| C | 233649 | 7 | |
| D | 233649 | 1 | |
| E | 233649 | 5 | |

51625000 51626000

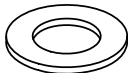
| Réf./No. | Réf./Art. | Qty./Stck./Quantité | ✓ |
|----------|-----------|---------------------|---|
| A | 23364910 | 15 | |
| B | 23364910 | 4 | |
| C | 23364910 | 7 | |
| D | 23364910 | 1 | |
| E | 23364910 | 5 | |

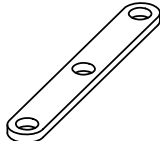
| 15 - A | 4 - B | 7 - C | 1 - D | 5 - E | |
|---|---|---|---|---|--|
|  |  |  |  |  | |
| M8 x 25 mm | ∅8 mm | ∅8/∅16 mm | 5 mm | 150 x 20 x 5 mm | |
| | | | | | |
| | | | | | |
| | | | | | |

Geehrter Kunde.
Hier haben Sie die Möglichkeit die mitgelieferten
Schrauben nachzumessen.

Cher Client.
La règle ci jointe vous permet de mesurer la visserie.

Estimado cliente.
aquí podrá medir la tornillería adjunta.

Kære kunde.
Her har De muligheden for at måle medsendte beslag.

Dear Customer.
Below you have the opportunity to measure the
Enclosed Hardware.

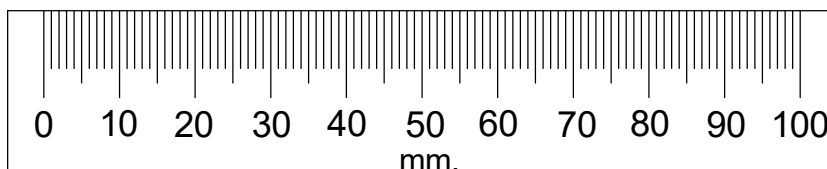

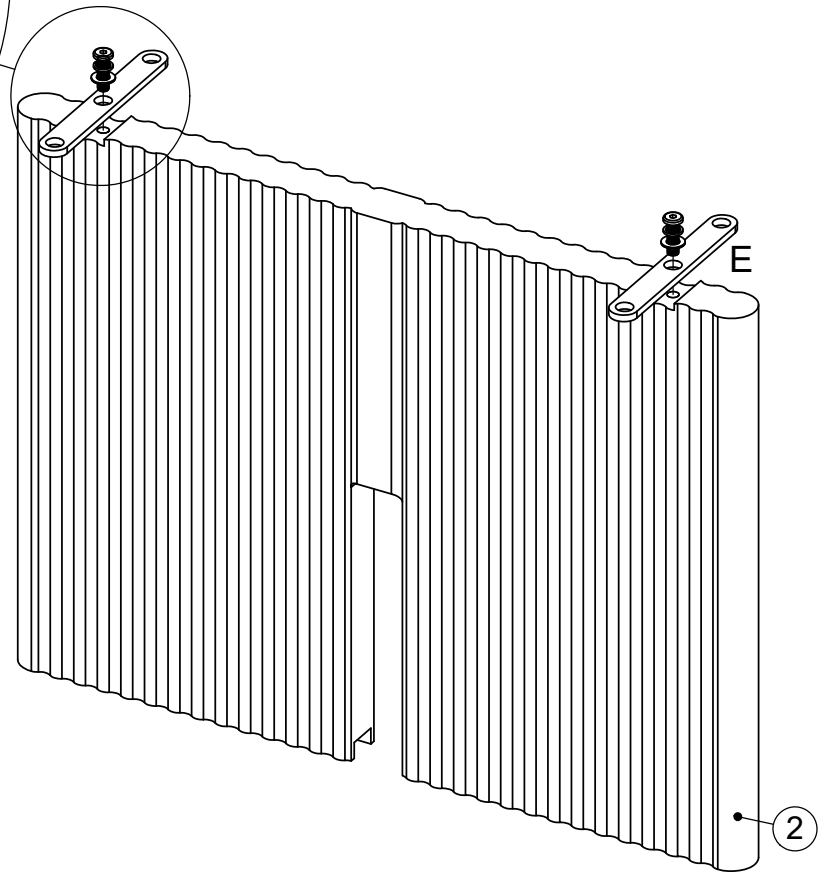
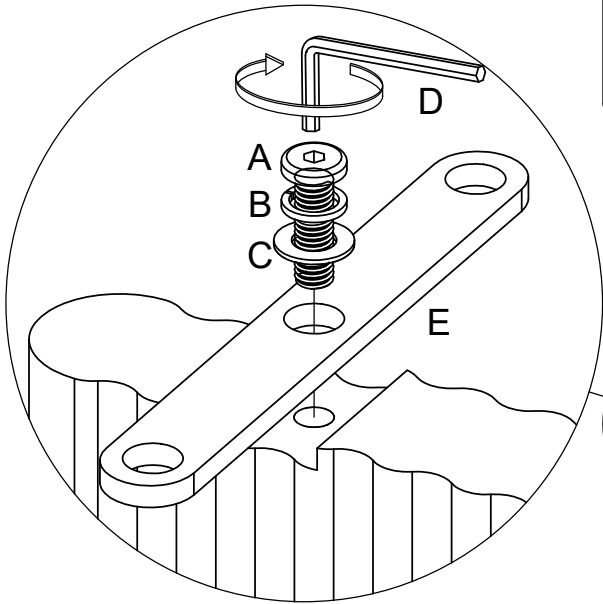
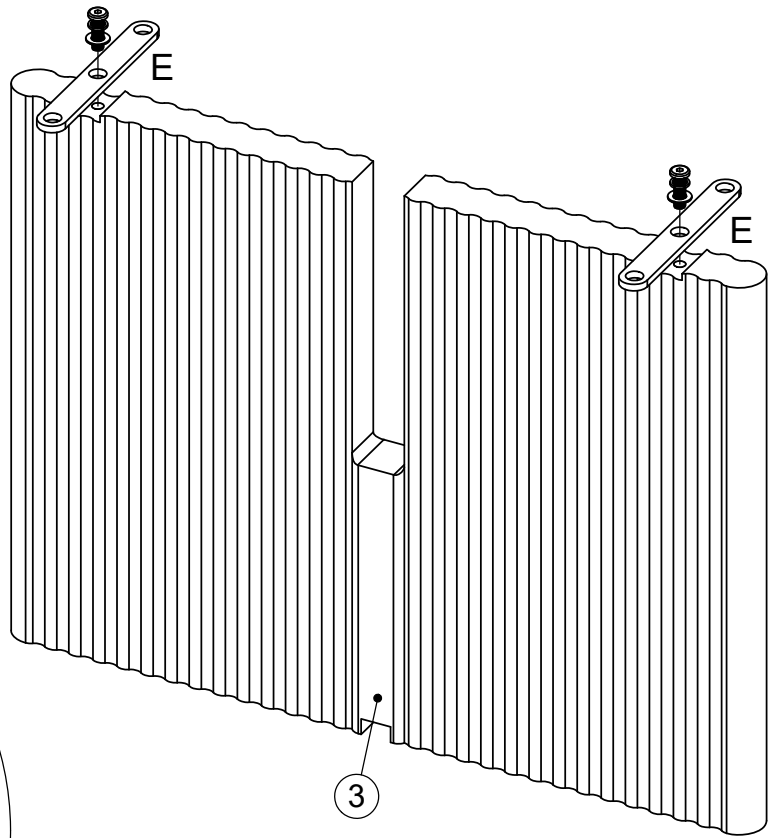
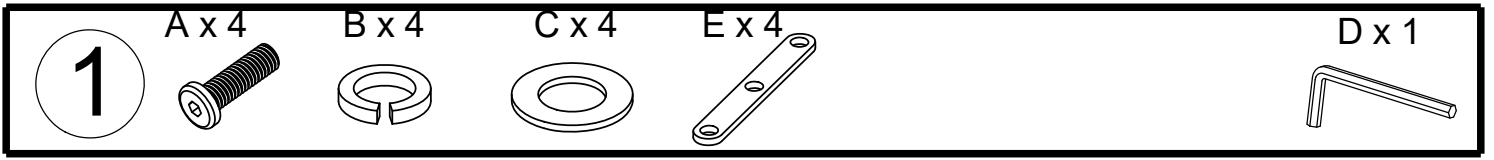

2

A x 4



D x 1

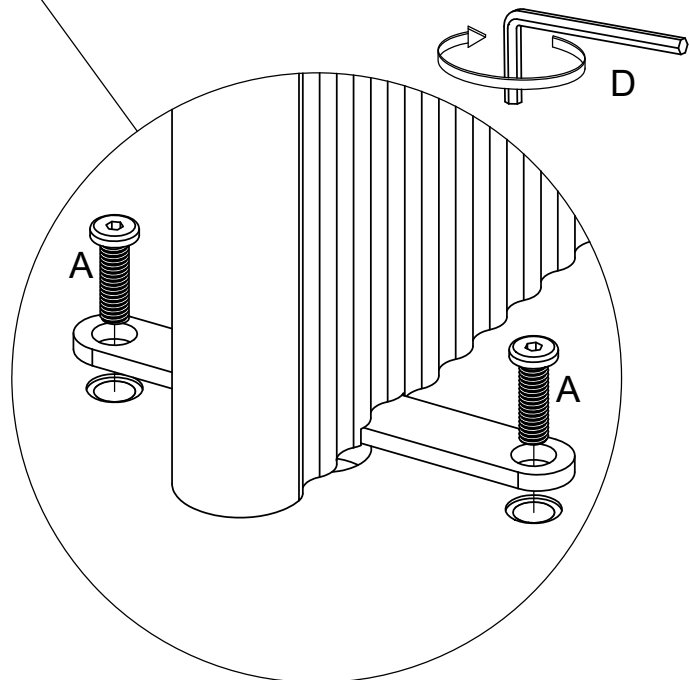
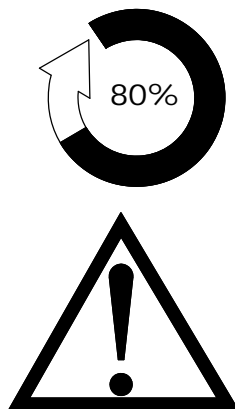
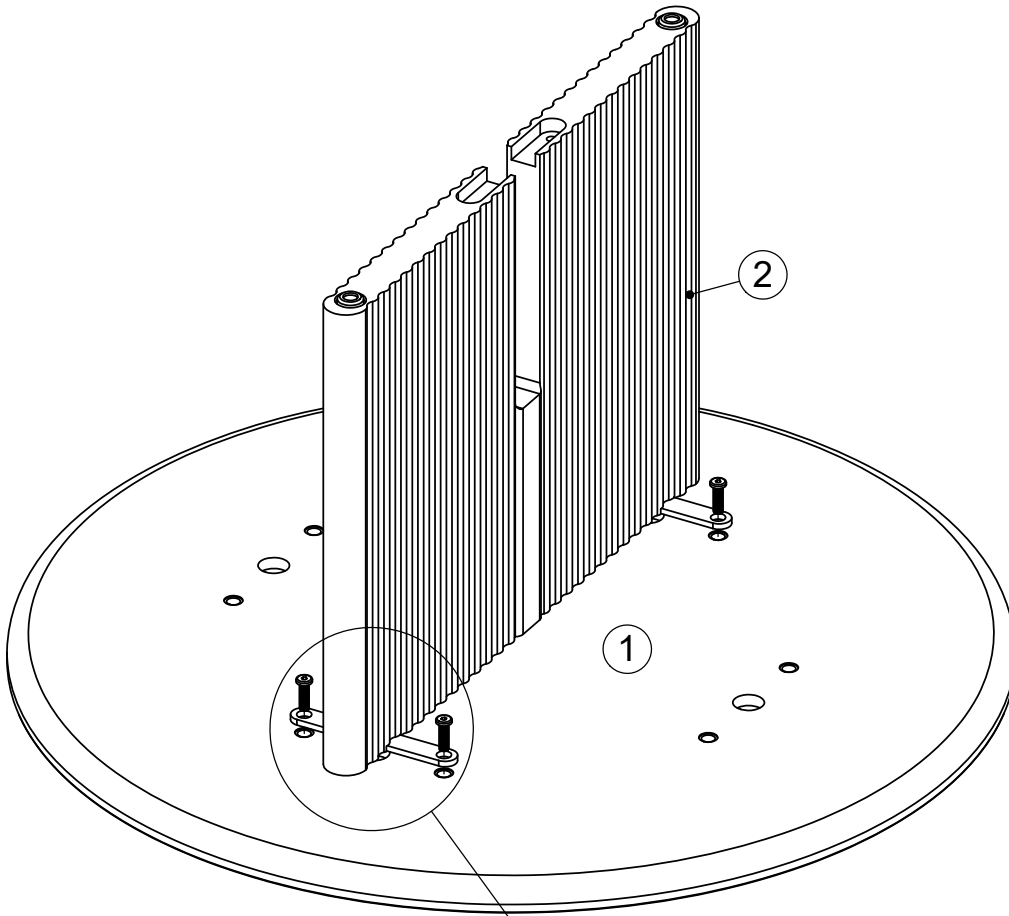

3

A x 4



D x 1

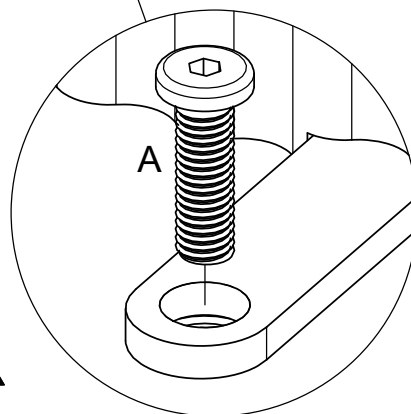
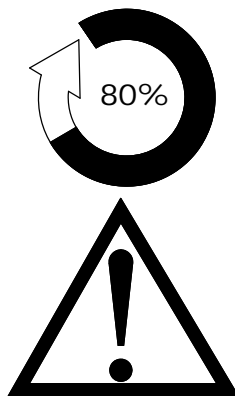
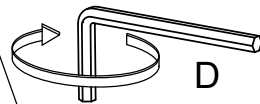
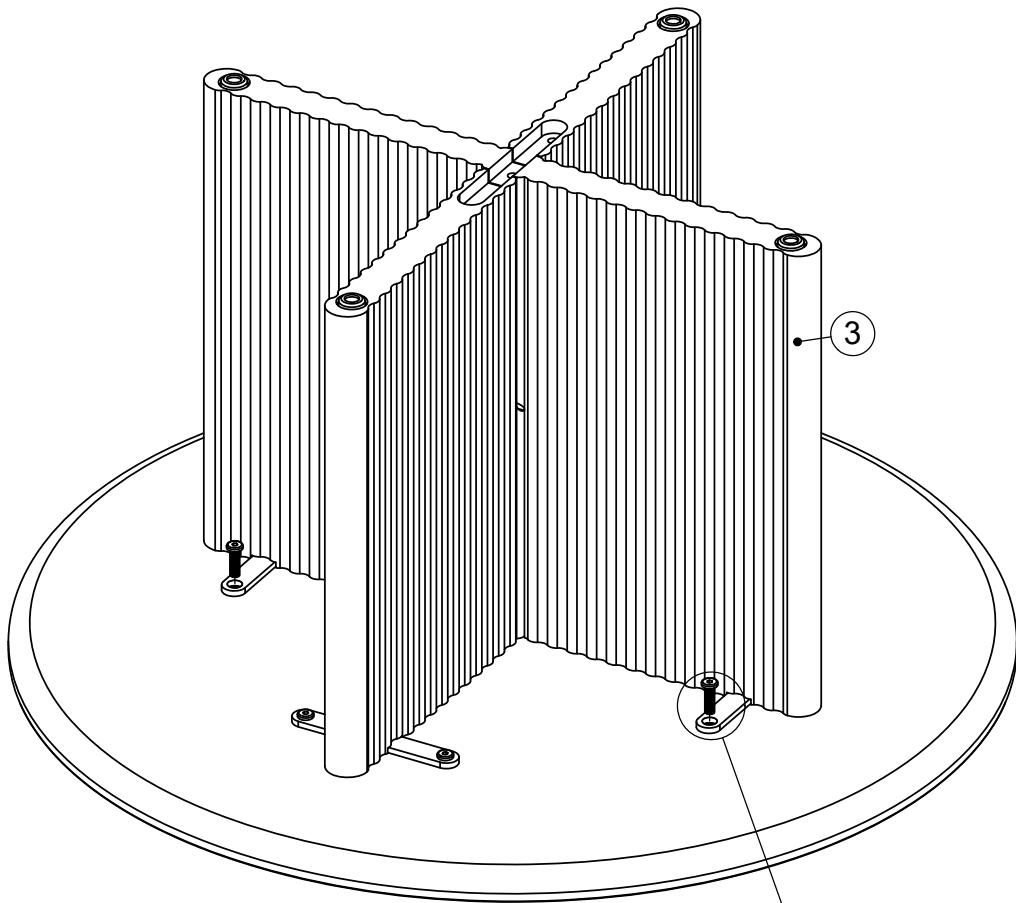

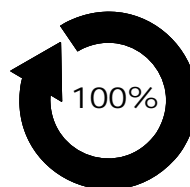
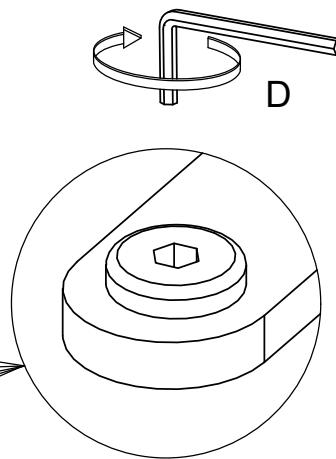
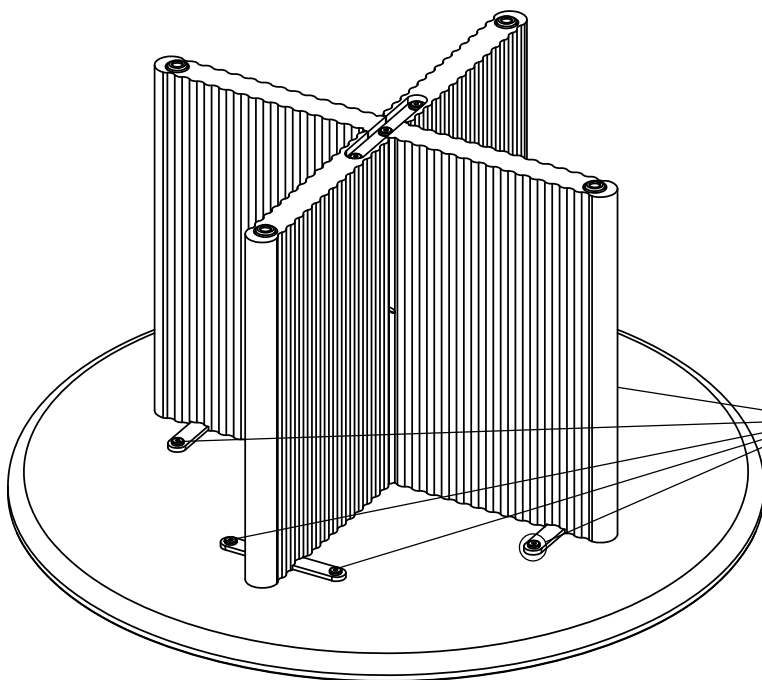
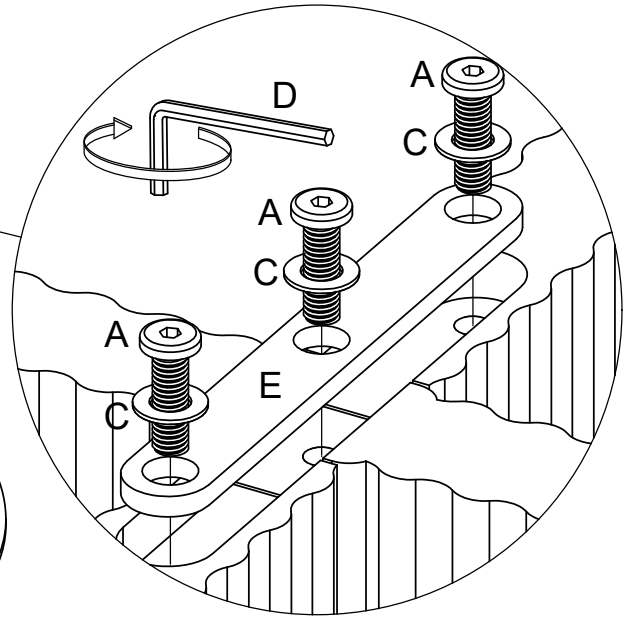
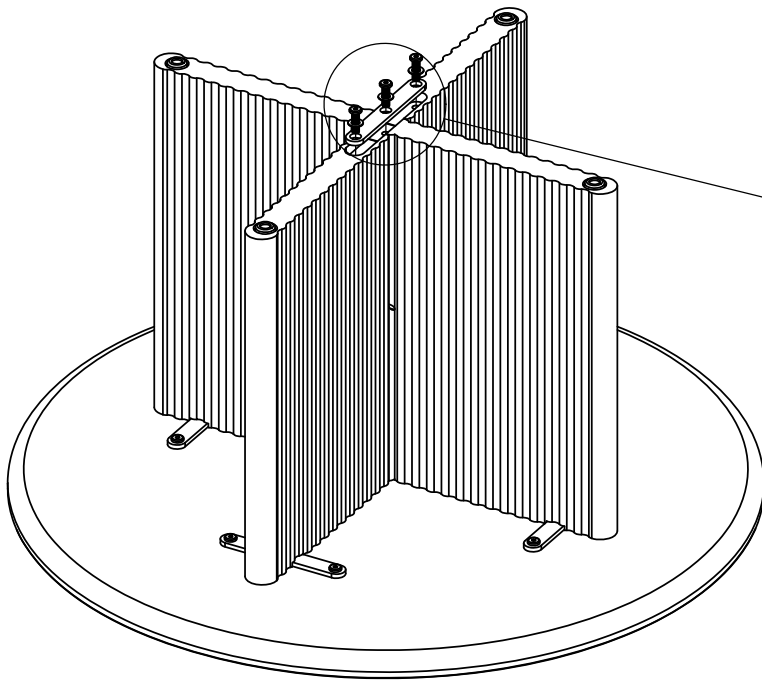
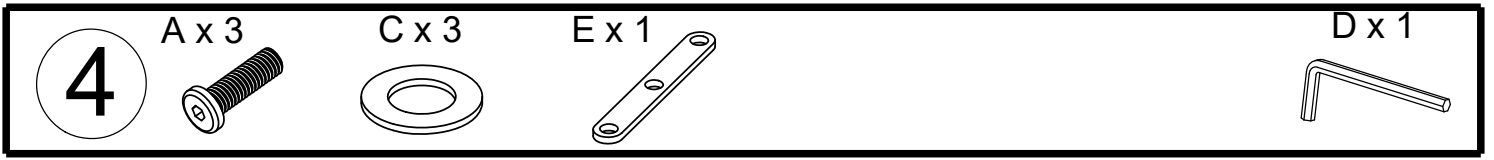

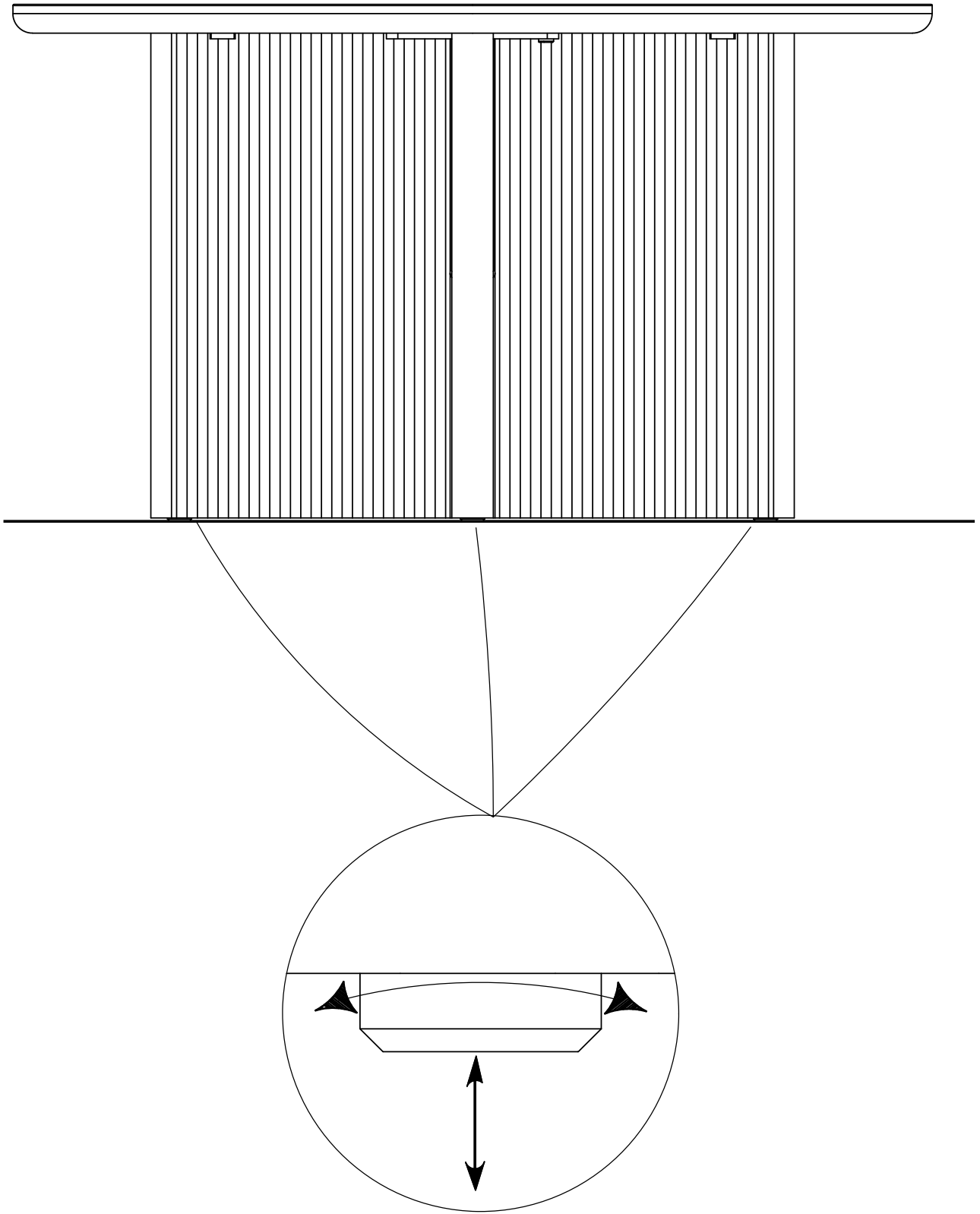

6

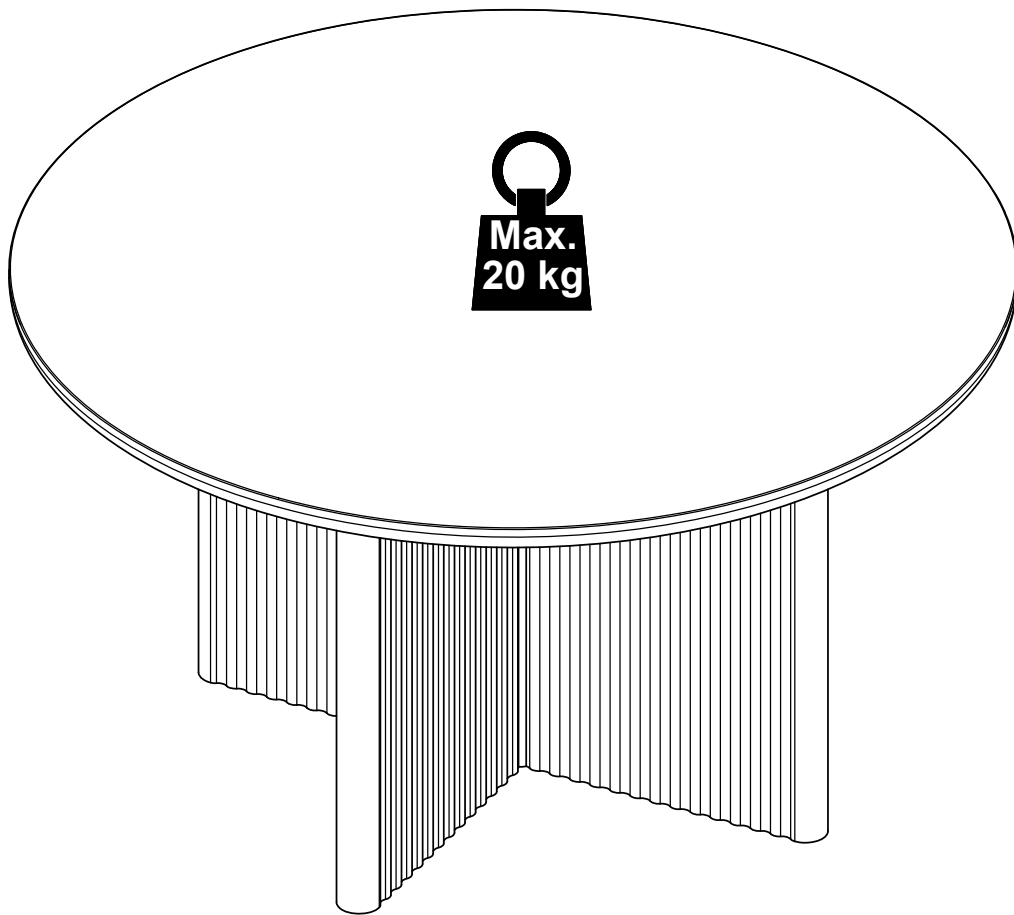



UK:

It is important that any product which is assembled using any kind of screw is re-tightened 2 weeks after assembly, and once every 3 months - in order to assure stability through-out the lifespan of the product.

DE:

Es ist wichtig, bei jedem mit Schrauben montierten Produkt diese 2 Wochen nach dem Zusammenbau sowie einmal alle 3 Monate wieder anzuziehen, um die Stabilität des Produkts über die gesamte Lebensdauer hinweg zu gewährleisten.

ES:

En el caso de los productos ensamblados, es importante volver a apretar los tornillos 2 semanas después del montaje y después cada 3 meses, para así preservar la estabilidad durante toda la vida útil del producto.

FR:

Il est important que tout produit monté à l'aide de vis soit resserré 2 semaines après son montage, puis tous les 3 mois, afin de garantir sa stabilité durant tout son cycle de vie.

DK: VIGTIGT!

Det er vigtigt, at alle produkter, der samles med alle former for skruer, efterspændes to uger efter samling samt hver tredje måned for at sikre, at produktet er stabilt i hele dets levetid.