

DAVI

MESA REDON. DAVI 80CM
ROUND TABLE. DAVI 80CM
TABLE RONDE DAVI 80CM

19834 EAN Code: 8435178350992

19835 EAN Code: 8435178351012

Instrucciones de Montaje
Assembly Instructions
Notice de Montage
Istruzioni di Montaggio
Instruções de Montagem
Montageanleitung

Version 10/21/2025

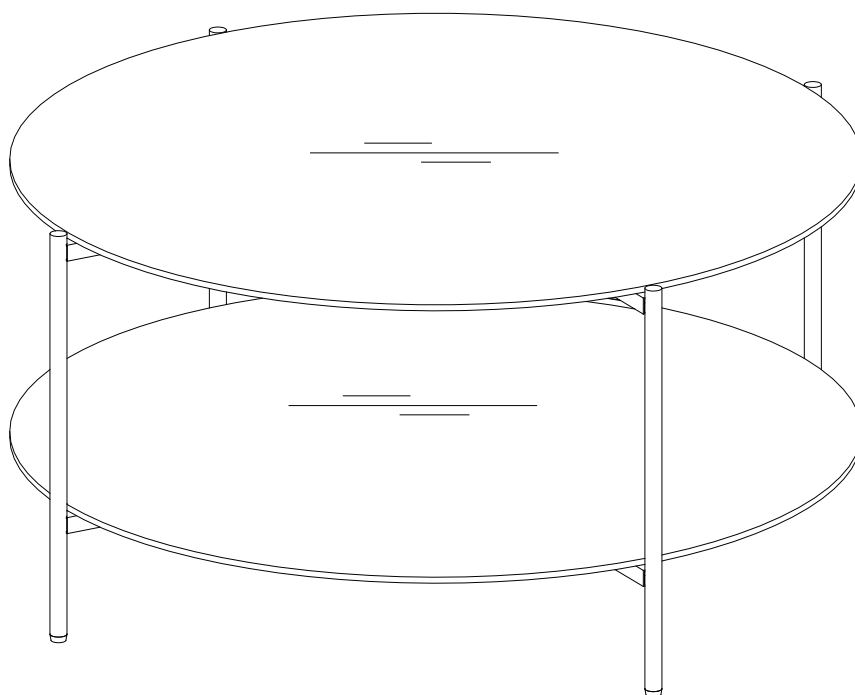

MARCKERIC S.L.
c/ Enlace Verola S/N
46430 Sollana - Valencia (SPAIN)
ventas@marckeric.com

MARCKERIC



- ES:** → **IMPORTANTE:** Antes de empezar, este mueble requiere montaje. Lea atentamente las instrucciones de montaje y consérvelas para futuras consultas.
- Este mueble es para uso doméstico
 - Compruebe que tiene toda la tornillería y todas las piezas antes de empezar el montaje.
 - No monte ni utilice el mueble si hubiera piezas rotas o dañadas o si faltaran piezas, y emplee únicamente piezas aprobadas por el fabricante.
 - Apriete firmemente las fijaciones y emplee únicamente las herramientas suministradas o recomendadas.
 - El montaje, el apuntalamiento o la manipulación incorrectos podrían debilitar el ensamblado de las piezas.
 - Mantenga a los niños alejados durante el montaje. El producto contiene piezas pequeñas que podrían ingerirse.
 - Todas las uniones deberán apretarse adecuadamente y verificarse periódicamente, volviéndolas a apretar si fuera necesario. La mesa no está diseñado para volverse a montar.
 - No desplace un mueble que esté cargado.
 - No se sienta sobre la mesa.
 - Antes del uso, asegúrese de que el tablero de la mesa esté bloqueado correctamente en su sitio. Tenga cuidado de no atraparse los dedos al cambiar la mesa de posición.
- EN:** → **IMPORTANT:** Before starting, this furniture self-assembly required. Please read the assembly instructions carefully and keep them for future reference.
- This furniture is for domestic use.
 - Check that all of the hardware and parts are present and in good condition before starting assembly.
 - Do not assemble or use the furniture if any of the parts are broken, damaged or missing, and only use parts approved by the manufacturer.
 - Firmly tighten the fasteners and use only the tools supplied or recommended.
 - Improper assembly, cribbing or handling can lead to assemblies and/or parts becoming weakened.
 - Keep young children away during assembly. The product contains small parts that could be ingested.
 - All joints should always be properly tightened and regularly checked, and retightened, if necessary. Table is not intended to be reassembled.
 - Do not move furniture that is loaded.
 - Do not sit on the table.
 - Before use, make sure the tabletop is properly locked in place. Be careful not to pinch your fingers when lowering the table into position.
- FR:** → **IMPORTANT:** Avant de commencer, ce meuble a monter soi-même. Lisez attentivement les notices de montage et conservez-les pour référence ultérieure.
- Ce meuble est à usage domestique.
 - Vérifier la présence et l'état de la quincaillerie et des pièces avant de débiter le montage.
 - Ne pas monter ou utiliser le mobilier si certains éléments sont cassés, endommagés ou manquants, et n'utiliser que des pièces approuvées par le fabricant.
 - Serrez fermement les fixations et utilisez uniquement les outils fournis ou recommandés.
 - Un mauvais montage, calage ou manutention incorrects pourraient affaiblir l'assemblage des pièces.
 - Tenir éloigné les jeunes enfants lors de l'assemblage. Présence de petites pièces susceptibles d'être ingérées.
 - Il convient que tous les dispositifs d'assemblage soient toujours convenablement serrés et régulièrement vérifiés, et resserrés, si nécessaire. Mobilier non prévu pour être remonté.
 - Ne pas déplacer un mobilier chargé.
 - Ne vous asseyez pas sur la table.
 - Avant utilisation, assurez-vous que le plateau de la table est correctement verrouillé. Faites attention à ne pas vous pincer les doigts en abaissant la table.

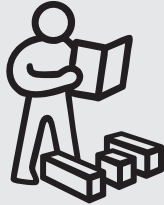

- IT:** → **IMPORTANTE:** Prima di cominciare, questo mobile richiede da assemblare. Leggere attentamente le istruzioni di montaggio e conservarle per riferimenti futuri.
- Questo mobile è destinato all'uso domestico.
 - Verificare la presenza e lo stato dei dispositivi di fissaggio e dei componenti prima di iniziare il montaggio.
 - Non montare né utilizzare il mobile se ci sono pezzi rotti, danneggiati o mancanti. Utilizzare solo componenti approvati dal produttore.
 - Serrare saldamente i dispositivi di fissaggio e utilizzare solo gli utensili forniti o raccomandati.
 - Un montaggio, rinforzo o manipolazione scorretti possono indebolire la struttura.
 - Tenere i bambini lontani durante il montaggio. Il prodotto contiene piccole parti che potrebbero essere ingerite.
 - Si raccomanda di verificare regolarmente il corretto serraggio dei dispositivi di assemblaggio; serrarli se necessario. Il mobile non è progettato per essere smontato e rimontato.
 - Non spostare un mobile carico.
 - Non sedersi sul tavolo.
 - Prima dell'uso, assicurarsi che il piano del tavolo sia bloccato correttamente in posizione. Fare attenzione a non pizzicarsi le dita durante l'abbassamento del tavolo.
- PT:** → **IMPORTANTE:** Antes de começar, este móvel requer montagem. Leia atentamente as instruções e guarde-as para futuras consultas.
- Este móvel é para uso doméstico.
 - Verifique se possui todos os parafusos e peças antes de iniciar a montagem.
 - Não monte nem utilize o móvel se houver peças partidas, danificadas ou em falta. Utilize apenas peças aprovadas pelo fabricante.
 - Aperte bem todas as fixações e utilize apenas as ferramentas fornecidas ou recomendadas.
 - Montagem, reforço ou manuseio incorretos podem enfraquecer a estrutura.
 - Mantenha as crianças afastadas durante a montagem. O produto contém peças pequenas que podem ser ingeridas.
 - Todas as uniões devem ser apertadas adequadamente e verificadas periodicamente, reapertando-as se necessário. O móvel não foi projetado para ser remontado.
 - Não mova o móvel quando estiver carregado.
 - Não se sente sobre a mesa.
 - Antes de usar, certifique-se de que o tampo da mesa está corretamente travado no lugar. Tenha cuidado para não prender os dedos ao abaixar a mesa.
- DE:** → **WICHTIG:** Vor dem Beginn muss dieses Möbelstück montiert werden. Lesen Sie die Montageanleitung sorgfältig durch und bewahren Sie sie für spätere Nachschlagezwecke auf.
- Dieses Möbel ist für den Hausgebrauch bestimmt.
 - Überprüfen Sie, ob alle Schrauben und Teile vorhanden sind, bevor Sie mit der Montage beginnen.
 - Montieren oder benutzen Sie das Möbel nicht, wenn Teile beschädigt, defekt oder fehlend sind. Verwenden Sie nur vom Hersteller zugelassene Teile.
 - Ziehen Sie alle Befestigungen fest an und verwenden Sie nur die mitgelieferten oder empfohlenen Werkzeuge.
 - Eine unsachgemäße Montage, Abstützung oder Handhabung kann die Stabilität beeinträchtigen.
 - Halten Sie Kinder während der Montage fern. Das Produkt enthält Kleinteile, die verschluckt werden könnten.
 - Alle Verbindungen müssen fest angezogen und regelmäßig überprüft und bei Bedarf nachgezogen werden. Das Möbelstück ist nicht für eine erneute Demontage und Montage vorgesehen.
 - Bewegen Sie keine Möbelstücke, die beladen sind.
 - Nicht auf den Tisch setzen.
 - Vor der Benutzung sicherstellen, dass die Tischplatte korrekt eingerastet ist. Achten Sie darauf, sich beim Absenken der Tischplatte nicht die Finger einzuklemmen.



ES: → El montaje requiere de dos personas.
 → Estas herramientas son necesarias para el montaje pero no están incluidas.
 → No utilizar herramientas eléctricas.
 → Tiempo de montaje estimado.

EN: → Assembly requires two people.
 → These tools are necessary for assembly but are not included.
 → Do not use power tools.
 → Estimated assembly time.

FR: → Le montage nécessite deux personnes.
 → Ces outils sont nécessaires pour le montage mais ne sont pas inclus.
 → N'utilisez pas d'outils électriques.
 → Temps de montage estimé.

IT: → Il montaggio richiede due persone.
 → Questi strumenti sono necessari per il montaggio ma non sono inclusi.
 → Non utilizzare utensili elettrici.
 → Tempo di montaggio stimato.

PT: → A montagem requer duas pessoas.
 → Estas ferramentas são necessárias para a montagem, mas não estão incluídas.
 → Não utilize ferramentas elétricas.
 → Tempo estimado de montagem.

DE: → Für die Montage werden zwei Personen benötigt.
 → Diese Werkzeuge sind für die Montage erforderlich, aber nicht enthalten.
 → Keine Elektrowerkzeuge verwenden.
 → Geschätzte Montagezeit.



ES: Composición del producto
 Cristal y metal

EN: Product Composition
 Glass and metal

FR: Composition du produit
 Verre et méta

IT: Composizione del prodotto
 Vetro e metallo

PT: Composição do produto
 Vidro e metal

DE: Produktzusammensetzung
 Glas und Metall



ES: Después de montar este producto, es aconsejable ventilar la habitación frecuentemente, durante algunos días.

EN: After assembling this product, it is recommended to regularly ventilate the room for a few days.

FR: Après assemblage de ce produit, il est conseillé d'aérer régulièrement la pièce pendant quelques jours.

IT: Dopo aver montato il prodotto si consiglia di ventilare la stanza per alcuni giorni.

PT: Depois de montar este produto, é aconselhável ventilar o ambiente com frequência, durante alguns dias.

DE: Nach dem Aufbau dieses Produkts wird empfohlen, den Raum für einige Tage regelmäßig zu lüften.



1PC / 1CTN

Caja Box Colis	Tamaño de la caja Box dimensions Dimensions colis	Peso neto Net weight Podis net	Peso bruto Gross weight Podis brut
1/1	960x950x127 mm	17.8kg	22kg



ES: Peso máximo recomendado.
 EN: Maximum weight recommended.
 FR: Poids maximum recommandé.

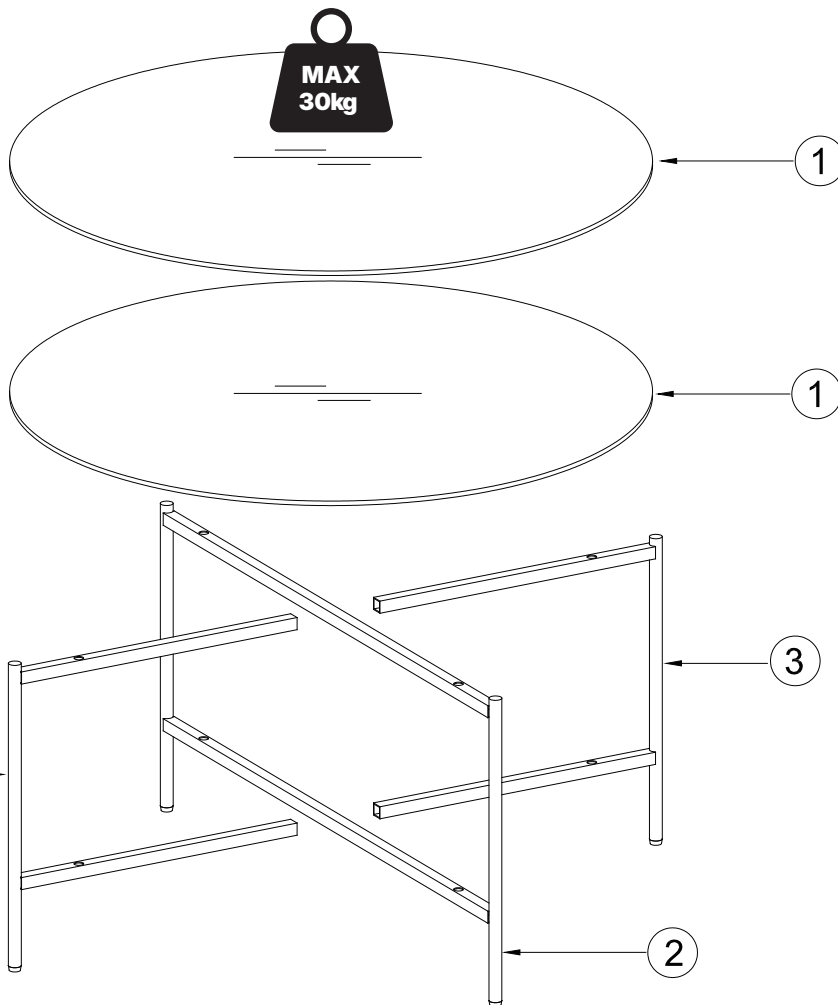

Caja-Box-Colis 1/1	
Piece 01 x 2 un.	
Piece 02 x 1 un.	
Piece 03 x 2 un.	
Herrajes Hardware Quincaillerie	Hoja de montaje Assembly sheet Notice de montage

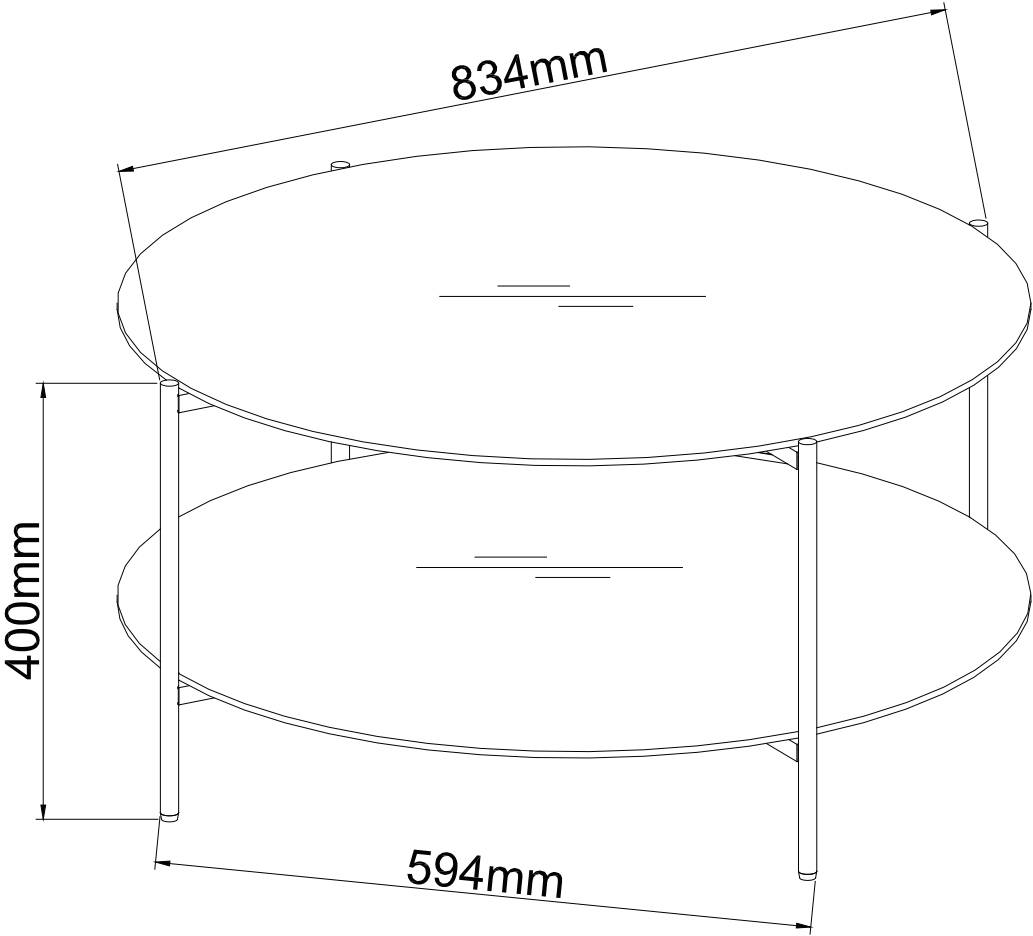

Listado de piezas - Parts list - Composants

01

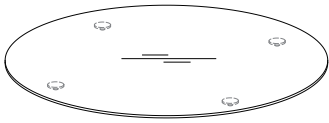

800x800x18 mm

2 un.

02

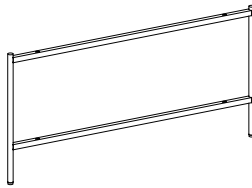

834x400x16 mm

1 un.

03

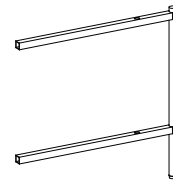

409x400x16 mm

2 un.

Herrajes - Hardware - Quincaillerie

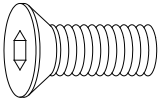
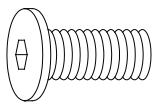
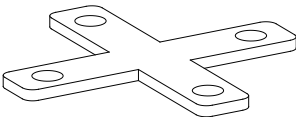
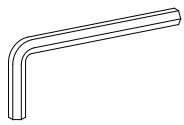
<p>A</p>  <p>8 un.</p>	<p>B</p>  <p>8 un.</p>	<p>C</p>  <p>2 un.</p>	<p>D</p>  <p>1 un.</p>
---	---	--	---

Herrajes - Hardware - Quincaillerie

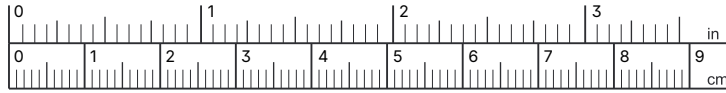

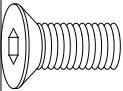
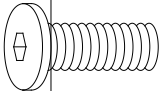
A x8 un.		6x15 mm
B x8 un.		6x15 mm



ES: Atornille con cuidado. Forzar el ajuste puede dañar el mueble.

EN: Screw carefully. Forcing the fit may damage the furniture.

FR: Vissez avec précaution. Forcer l'ajustement peut endommager le meuble.



1



A x 6 ud.



C x 2 ud.



D x 1 ud.



ES: Utilice una manta para evitar daños al mueble.

EN: Use a cover to avoid damage the furniture.

FR: Utilisation d'une couverture recommandée pour ne pas abimer le meuble.

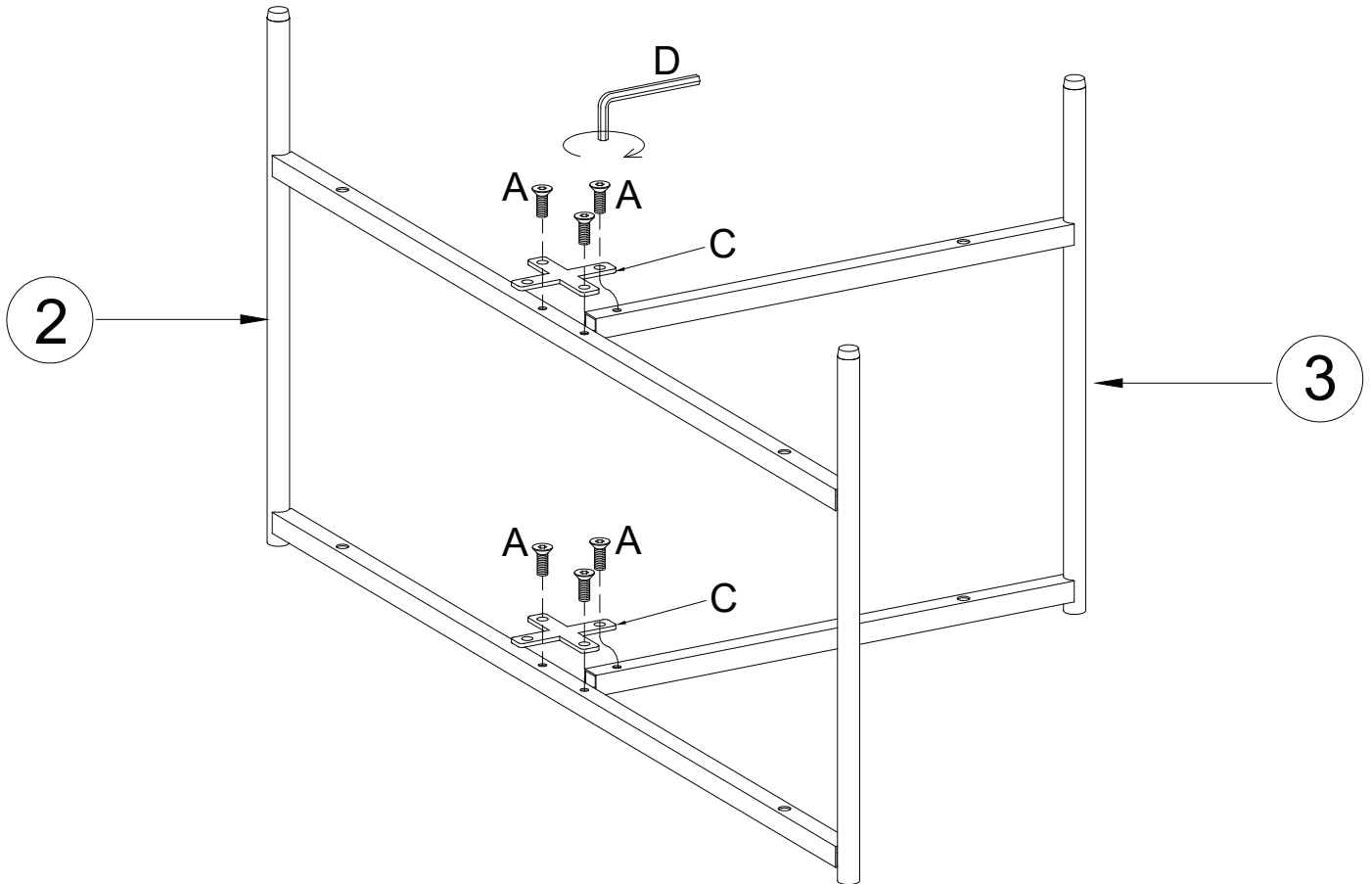
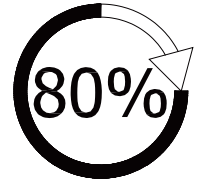

2



1

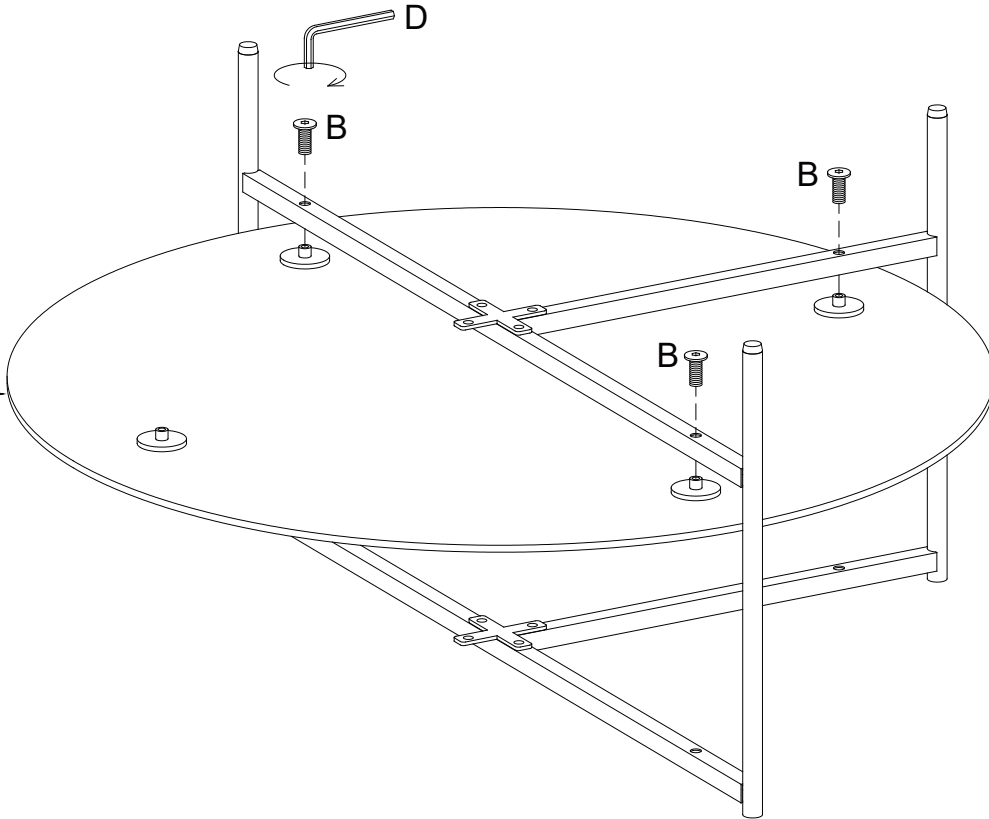

3

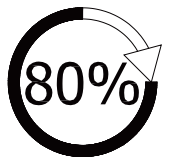
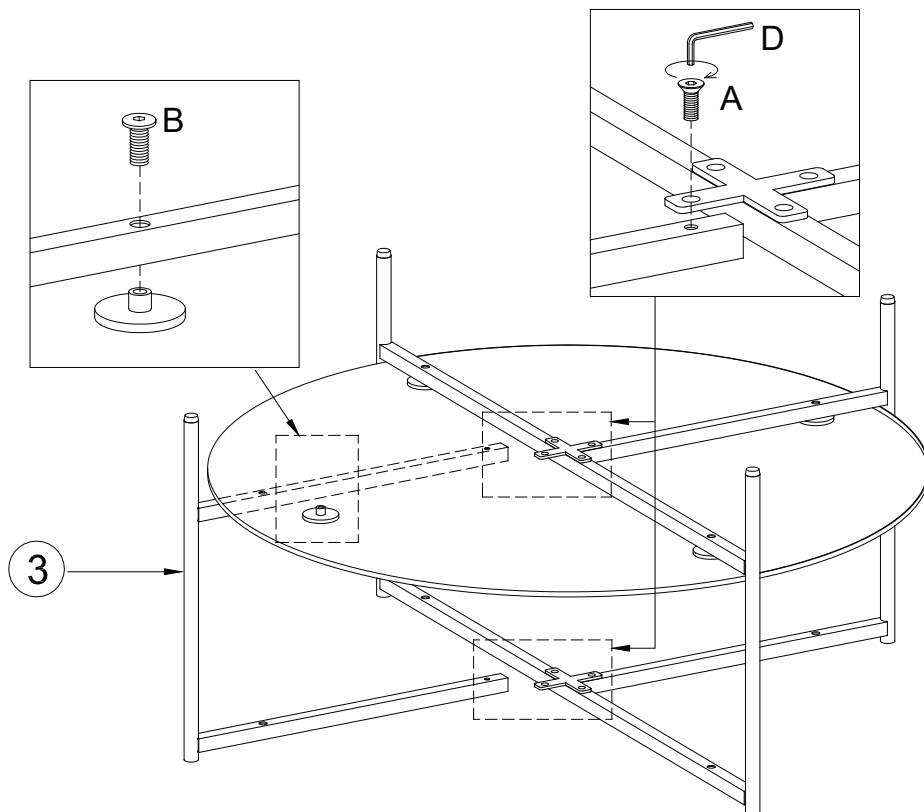

4



B x 4 ud.



D x 1 ud.

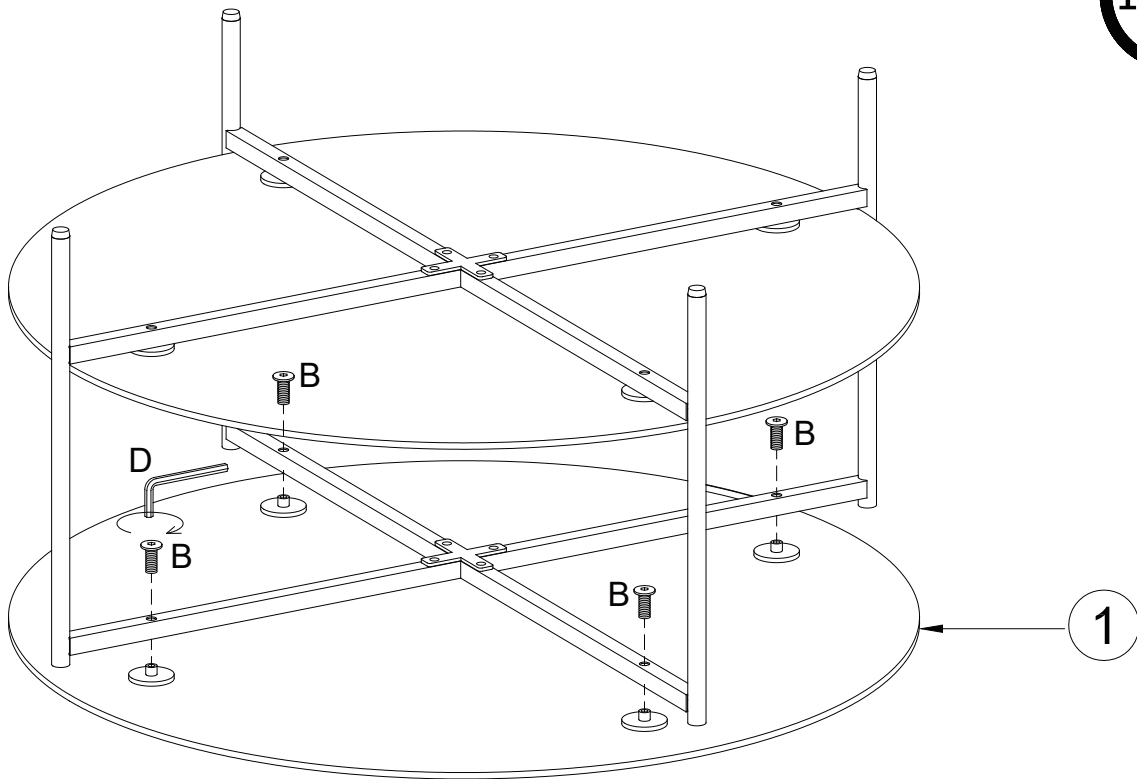
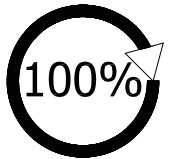

5



ES: Girar el mueble con cuidado.
EN: Turn the furniture careful.
FR: Basculer le meuble avec précaution.

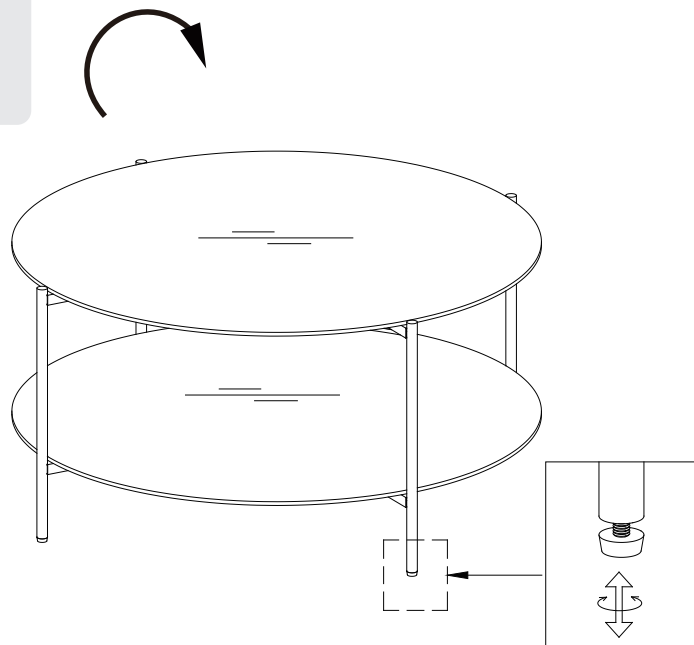

6



ES: En caso de reclamación, por favor, facilite la información que aparece en la etiqueta I D.

EN: If you may have whatever complaint, please, let us know the information written on the ID label

FR: En cas de réclamation, merci de transmettre les informations contenues sur l'étiquette fixée sur le produit.

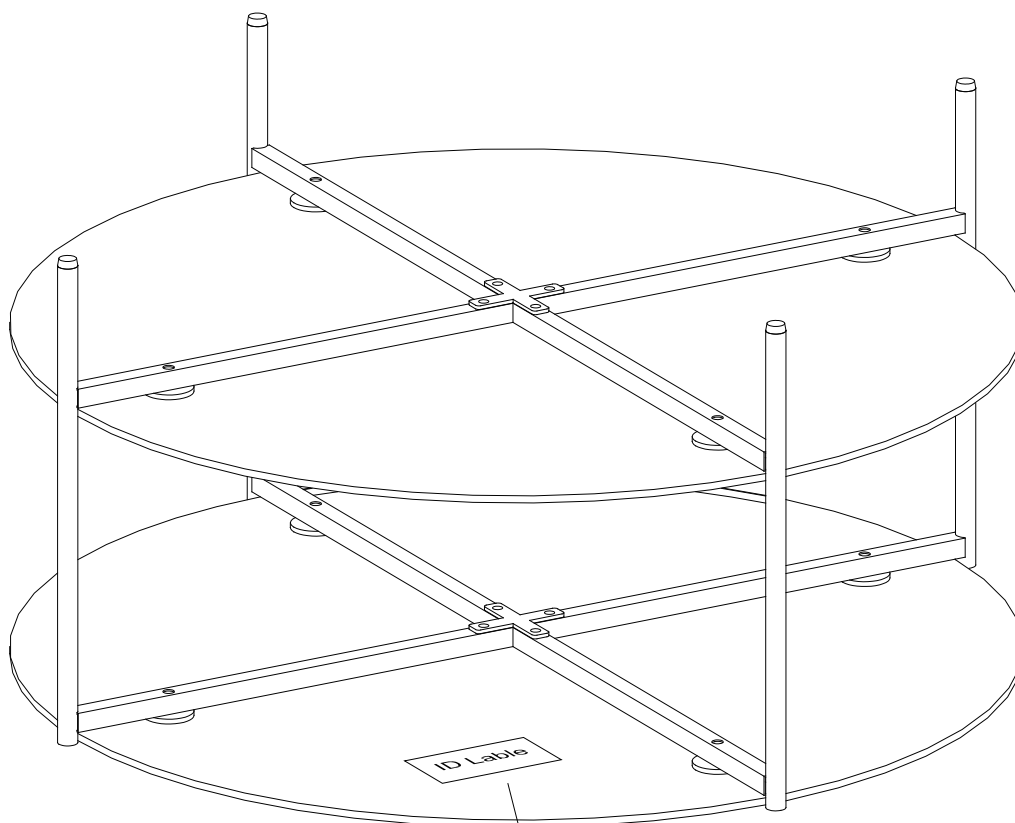

ID Label



Consejos de montaje

1. Lea atentamente las instrucciones de montaje.
2. Identifique los componentes del mueble.
3. Agrupe y revise la tornillería.
4. Use las herramientas necesarias.
5. Prepare una zona de montaje.
6. Monte el mueble.



Consejos de mantenimiento y limpieza

- Nunca fuerce las uniones.
- Apriete los tornillos después de un tiempo de uso.
- Conserve el manual de montaje; si falta alguna pieza, es la forma más fácil de contactar con la tienda.
- No utilice productos abrasivos, lana de acero ni disolventes.
- No moje el producto.
- Quite cuidadosamente el polvo.
- Utilice un paño ligeramente humedecido.

Instrucciones de mantenimiento
Paño suave ligeramente húmedo
Agua con jabón
Agua con detergente
Esponja anti-rayaduras
Mantenimiento específico del fabricante

Materiales												
Madera maciza acedada	Madera encerada	Madera barnizada o teñida	Panel de madera con papel decorativo	Paneles recubiertos de melamina	Superficie lacada	Piedras	Cuero	Metal	Plástico	Textil	Textil revestido (PU, PVC)	Producto con partes eléctricas
<input type="checkbox"/>	<input type="checkbox"/>	<input type="checkbox"/>	<input type="checkbox"/>	<input type="checkbox"/>	<input type="checkbox"/>	<input type="checkbox"/>	<input type="checkbox"/>	<input type="checkbox"/>	<input type="checkbox"/>	<input type="checkbox"/>	<input type="checkbox"/>	<input type="checkbox"/>
<input type="checkbox"/>	<input type="checkbox"/>	<input type="checkbox"/>	<input type="checkbox"/>	<input type="checkbox"/>	<input type="checkbox"/>	<input type="checkbox"/>	<input type="checkbox"/>	<input type="checkbox"/>	<input type="checkbox"/>	<input type="checkbox"/>	<input type="checkbox"/>	<input type="checkbox"/>
<input type="checkbox"/>	<input type="checkbox"/>	<input type="checkbox"/>	<input type="checkbox"/>	<input type="checkbox"/>	<input type="checkbox"/>	<input type="checkbox"/>	<input type="checkbox"/>	<input type="checkbox"/>	<input type="checkbox"/>	<input type="checkbox"/>	<input type="checkbox"/>	<input type="checkbox"/>
<input type="checkbox"/>	<input type="checkbox"/>	<input type="checkbox"/>	<input type="checkbox"/>	<input type="checkbox"/>	<input type="checkbox"/>	<input type="checkbox"/>	<input type="checkbox"/>	<input type="checkbox"/>	<input type="checkbox"/>	<input type="checkbox"/>	<input type="checkbox"/>	<input type="checkbox"/>

Advertencias
Antes de cualquier mantenimiento, limpie el polvo con cuidado
Cualquier mancha debe limpiarse rápidamente
No utilice productos abrasivos (polvo, lana de acero)
No utilice disolventes
No mojar
No limpiar con hidrolimpiadora (productos de exterior)

<input type="checkbox"/>	<input type="checkbox"/>	<input type="checkbox"/>	<input type="checkbox"/>	<input type="checkbox"/>	<input type="checkbox"/>	<input type="checkbox"/>	<input type="checkbox"/>	<input type="checkbox"/>	<input type="checkbox"/>	<input type="checkbox"/>	<input type="checkbox"/>	<input type="checkbox"/>
<input type="checkbox"/>	<input type="checkbox"/>	<input type="checkbox"/>	<input type="checkbox"/>	<input type="checkbox"/>	<input type="checkbox"/>	<input type="checkbox"/>	<input type="checkbox"/>	<input type="checkbox"/>	<input type="checkbox"/>	<input type="checkbox"/>	<input type="checkbox"/>	<input type="checkbox"/>
<input type="checkbox"/>	<input type="checkbox"/>	<input type="checkbox"/>	<input type="checkbox"/>	<input type="checkbox"/>	<input type="checkbox"/>	<input type="checkbox"/>	<input type="checkbox"/>	<input type="checkbox"/>	<input type="checkbox"/>	<input type="checkbox"/>	<input type="checkbox"/>	<input type="checkbox"/>
<input type="checkbox"/>	<input type="checkbox"/>	<input type="checkbox"/>	<input type="checkbox"/>	<input type="checkbox"/>	<input type="checkbox"/>	<input type="checkbox"/>	<input type="checkbox"/>	<input type="checkbox"/>	<input type="checkbox"/>	<input type="checkbox"/>	<input type="checkbox"/>	<input type="checkbox"/>
<input type="checkbox"/>	<input type="checkbox"/>	<input type="checkbox"/>	<input type="checkbox"/>	<input type="checkbox"/>	<input type="checkbox"/>	<input type="checkbox"/>	<input type="checkbox"/>	<input type="checkbox"/>	<input type="checkbox"/>	<input type="checkbox"/>	<input type="checkbox"/>	<input type="checkbox"/>

Información específica
Consulte la información adicional adjunta al producto.

<input type="checkbox"/>	<input type="checkbox"/>	<input type="checkbox"/>	<input type="checkbox"/>	<input type="checkbox"/>	<input type="checkbox"/>	<input type="checkbox"/>	<input type="checkbox"/>	<input type="checkbox"/>	<input type="checkbox"/>	<input type="checkbox"/>	<input type="checkbox"/>	<input type="checkbox"/>
--------------------------	--------------------------	--------------------------	--------------------------	--------------------------	--------------------------	--------------------------	--------------------------	--------------------------	--------------------------	--------------------------	--------------------------	--------------------------



Assembly advices

1. Carefully read the assembly instruction.
2. Identify the components of the furniture.
3. Group and check the hardware.
4. Use the required tools.
5. Create an assembly zone.
6. Make the assembly.



Maintenance and cleaning advices

- Never force the connections.
- Tighten the screws after a period of use.
- Keep the assembly manual; if a part is missing, it is the easiest way to contact the store.
- Do not use abrasive powders, steel wool or solvents.
- Do not wet.
- Carefully remove dust.
- Use a slightly damp cloth.

Materials												
Solid wood oiled	Waxed wood	Varnished or stained wood	Wood panel covered with decorative paper	Melamine covered panels	Lacquered surface	Stones	Leather	Metal	Plastic	Textile	Enducted textile (PU, PVC)	Product with electrical parts

Maintenance instructions
Slightly damp soft cloth
Soapy water
Water with detergent
Anti-scratch scouring sponge
Manufacturer specific maintenance

<input type="checkbox"/>	<input type="checkbox"/>	<input type="checkbox"/>	<input type="checkbox"/>	<input type="checkbox"/>	<input type="checkbox"/>	<input type="checkbox"/>	<input type="checkbox"/>	<input type="checkbox"/>	<input type="checkbox"/>	<input type="checkbox"/>	<input type="checkbox"/>	<input type="checkbox"/>
<input type="checkbox"/>	<input type="checkbox"/>	<input type="checkbox"/>	<input type="checkbox"/>	<input type="checkbox"/>	<input type="checkbox"/>	<input type="checkbox"/>	<input type="checkbox"/>	<input type="checkbox"/>	<input type="checkbox"/>	<input type="checkbox"/>	<input type="checkbox"/>	<input type="checkbox"/>
<input type="checkbox"/>	<input type="checkbox"/>	<input type="checkbox"/>	<input type="checkbox"/>	<input type="checkbox"/>	<input type="checkbox"/>	<input type="checkbox"/>	<input type="checkbox"/>	<input type="checkbox"/>	<input type="checkbox"/>	<input type="checkbox"/>	<input type="checkbox"/>	<input type="checkbox"/>
<input type="checkbox"/>	<input type="checkbox"/>	<input type="checkbox"/>	<input type="checkbox"/>	<input type="checkbox"/>	<input type="checkbox"/>	<input type="checkbox"/>	<input type="checkbox"/>	<input type="checkbox"/>	<input type="checkbox"/>	<input type="checkbox"/>	<input type="checkbox"/>	<input type="checkbox"/>
<input type="checkbox"/>	<input type="checkbox"/>	<input type="checkbox"/>	<input type="checkbox"/>	<input type="checkbox"/>	<input type="checkbox"/>	<input type="checkbox"/>	<input type="checkbox"/>	<input type="checkbox"/>	<input type="checkbox"/>	<input type="checkbox"/>	<input type="checkbox"/>	<input type="checkbox"/>

Warning
Before any maintenance, clean the dust carefully
Any stain should be cleaned quickly
Never use an abrasive product (powder, steel wool)
Never use solvent
Do not wet
Do not clean with high pressure cleaner (outdoor products)

<input type="checkbox"/>	<input type="checkbox"/>	<input type="checkbox"/>	<input type="checkbox"/>	<input type="checkbox"/>	<input type="checkbox"/>	<input type="checkbox"/>	<input type="checkbox"/>	<input type="checkbox"/>	<input type="checkbox"/>	<input type="checkbox"/>	<input type="checkbox"/>	<input type="checkbox"/>
<input type="checkbox"/>	<input type="checkbox"/>	<input type="checkbox"/>	<input type="checkbox"/>	<input type="checkbox"/>	<input type="checkbox"/>	<input type="checkbox"/>	<input type="checkbox"/>	<input type="checkbox"/>	<input type="checkbox"/>	<input type="checkbox"/>	<input type="checkbox"/>	<input type="checkbox"/>
<input type="checkbox"/>	<input type="checkbox"/>	<input type="checkbox"/>	<input type="checkbox"/>	<input type="checkbox"/>	<input type="checkbox"/>	<input type="checkbox"/>	<input type="checkbox"/>	<input type="checkbox"/>	<input type="checkbox"/>	<input type="checkbox"/>	<input type="checkbox"/>	<input type="checkbox"/>
<input type="checkbox"/>	<input type="checkbox"/>	<input type="checkbox"/>	<input type="checkbox"/>	<input type="checkbox"/>	<input type="checkbox"/>	<input type="checkbox"/>	<input type="checkbox"/>	<input type="checkbox"/>	<input type="checkbox"/>	<input type="checkbox"/>	<input type="checkbox"/>	<input type="checkbox"/>
<input type="checkbox"/>	<input type="checkbox"/>	<input type="checkbox"/>	<input type="checkbox"/>	<input type="checkbox"/>	<input type="checkbox"/>	<input type="checkbox"/>	<input type="checkbox"/>	<input type="checkbox"/>	<input type="checkbox"/>	<input type="checkbox"/>	<input type="checkbox"/>	<input type="checkbox"/>
<input type="checkbox"/>	<input type="checkbox"/>	<input type="checkbox"/>	<input type="checkbox"/>	<input type="checkbox"/>	<input type="checkbox"/>	<input type="checkbox"/>	<input type="checkbox"/>	<input type="checkbox"/>	<input type="checkbox"/>	<input type="checkbox"/>	<input type="checkbox"/>	<input type="checkbox"/>

Specific information
Check extra information attached on the product

<input type="checkbox"/>	<input type="checkbox"/>	<input type="checkbox"/>	<input type="checkbox"/>	<input type="checkbox"/>	<input type="checkbox"/>	<input type="checkbox"/>	<input type="checkbox"/>	<input type="checkbox"/>	<input type="checkbox"/>	<input type="checkbox"/>	<input type="checkbox"/>	<input type="checkbox"/>
--------------------------	--------------------------	--------------------------	--------------------------	--------------------------	--------------------------	--------------------------	--------------------------	--------------------------	--------------------------	--------------------------	--------------------------	--------------------------



Conseils de montage

1. Lisez attentivement les instructions de montage.
2. Identifiez les composants du meuble.
3. Regroupez et vérifiez la quincaillerie.
4. Utilisez les outils nécessaires.
5. Préparez une zone de montage.
6. Effectuez le montage.



Conseils d'entretien et de nettoyage

- Ne forcez jamais les connexions.
- Resserrez les vis après une période d'utilisation.
- Conservez le manuel de montage ; en cas de pièce manquante, c'est le moyen le plus simple de contacter le magasin.
- N'utilisez pas de poudres abrasives, laine d'acier ou solvants.
- Ne mouillez pas le produit.
- Enlevez délicatement la poussière.
- Utilisez un chiffon légèrement humide.

Instructions d'entretien	
Chiffon doux légèrement humide	<input type="checkbox"/>
Eau savonneuse	<input type="checkbox"/>
Eau avec détergent	<input type="checkbox"/>
Éponge non abrasive	<input type="checkbox"/>
Entretien spécifique du fabricant	<input type="checkbox"/>

Matériaux												
Bois massif huilé	Bois ciré	Bois verni ou teinté	Panneau bois avec papier décoratif	Panneaux revêtus de mélamine	Surface laquée	Pierres	Cuir	Métal	Plastique	Tissu	Tissu enduit (PU, PVC)	Produit avec éléments électriques

<input type="checkbox"/>	<input type="checkbox"/>	<input type="checkbox"/>	<input type="checkbox"/>	<input type="checkbox"/>	<input type="checkbox"/>	<input type="checkbox"/>	<input type="checkbox"/>	<input type="checkbox"/>	<input type="checkbox"/>	<input type="checkbox"/>	<input type="checkbox"/>	<input type="checkbox"/>
<input type="checkbox"/>	<input type="checkbox"/>	<input type="checkbox"/>	<input type="checkbox"/>	<input type="checkbox"/>	<input type="checkbox"/>	<input type="checkbox"/>	<input type="checkbox"/>	<input type="checkbox"/>	<input type="checkbox"/>	<input type="checkbox"/>	<input type="checkbox"/>	<input type="checkbox"/>
<input type="checkbox"/>	<input type="checkbox"/>	<input type="checkbox"/>	<input type="checkbox"/>	<input type="checkbox"/>	<input type="checkbox"/>	<input type="checkbox"/>	<input type="checkbox"/>	<input type="checkbox"/>	<input type="checkbox"/>	<input type="checkbox"/>	<input type="checkbox"/>	<input type="checkbox"/>
<input type="checkbox"/>	<input type="checkbox"/>	<input type="checkbox"/>	<input type="checkbox"/>	<input type="checkbox"/>	<input type="checkbox"/>	<input type="checkbox"/>	<input type="checkbox"/>	<input type="checkbox"/>	<input type="checkbox"/>	<input type="checkbox"/>	<input type="checkbox"/>	<input type="checkbox"/>
<input type="checkbox"/>	<input type="checkbox"/>	<input type="checkbox"/>	<input type="checkbox"/>	<input type="checkbox"/>	<input type="checkbox"/>	<input type="checkbox"/>	<input type="checkbox"/>	<input type="checkbox"/>	<input type="checkbox"/>	<input type="checkbox"/>	<input type="checkbox"/>	<input type="checkbox"/>

⚠ Avertissements ⚠	
Avant tout entretien, enlever la poussière avec soin	<input type="checkbox"/>
Toute tache doit être nettoyée rapidement	<input type="checkbox"/>
N'utilisez jamais de produit abrasif (poudre, laine d'acier)	<input type="checkbox"/>
N'utilisez jamais de solvant	<input type="checkbox"/>
Ne pas mouiller	<input type="checkbox"/>
Ne pas nettoyer avec un nettoyeur haute pression (produits extérieurs)	<input type="checkbox"/>

<input type="checkbox"/>	<input type="checkbox"/>	<input type="checkbox"/>	<input type="checkbox"/>	<input type="checkbox"/>	<input type="checkbox"/>	<input type="checkbox"/>	<input type="checkbox"/>	<input type="checkbox"/>	<input type="checkbox"/>	<input type="checkbox"/>	<input type="checkbox"/>	<input type="checkbox"/>
<input type="checkbox"/>	<input type="checkbox"/>	<input type="checkbox"/>	<input type="checkbox"/>	<input type="checkbox"/>	<input type="checkbox"/>	<input type="checkbox"/>	<input type="checkbox"/>	<input type="checkbox"/>	<input type="checkbox"/>	<input type="checkbox"/>	<input type="checkbox"/>	<input type="checkbox"/>
<input type="checkbox"/>	<input type="checkbox"/>	<input type="checkbox"/>	<input type="checkbox"/>	<input type="checkbox"/>	<input type="checkbox"/>	<input type="checkbox"/>	<input type="checkbox"/>	<input type="checkbox"/>	<input type="checkbox"/>	<input type="checkbox"/>	<input type="checkbox"/>	<input type="checkbox"/>
<input type="checkbox"/>	<input type="checkbox"/>	<input type="checkbox"/>	<input type="checkbox"/>	<input type="checkbox"/>	<input type="checkbox"/>	<input type="checkbox"/>	<input type="checkbox"/>	<input type="checkbox"/>	<input type="checkbox"/>	<input type="checkbox"/>	<input type="checkbox"/>	<input type="checkbox"/>
<input type="checkbox"/>	<input type="checkbox"/>	<input type="checkbox"/>	<input type="checkbox"/>	<input type="checkbox"/>	<input type="checkbox"/>	<input type="checkbox"/>	<input type="checkbox"/>	<input type="checkbox"/>	<input type="checkbox"/>	<input type="checkbox"/>	<input type="checkbox"/>	<input type="checkbox"/>

Informations spécifiques	
Consultez les informations supplémentaires jointes au produit.	<input type="checkbox"/>

<input type="checkbox"/>	<input type="checkbox"/>	<input type="checkbox"/>	<input type="checkbox"/>	<input type="checkbox"/>	<input type="checkbox"/>	<input type="checkbox"/>	<input type="checkbox"/>	<input type="checkbox"/>	<input type="checkbox"/>	<input type="checkbox"/>	<input type="checkbox"/>	<input type="checkbox"/>
--------------------------	--------------------------	--------------------------	--------------------------	--------------------------	--------------------------	--------------------------	--------------------------	--------------------------	--------------------------	--------------------------	--------------------------	--------------------------



Consigli di montaggio

1. Leggere attentamente le istruzioni di montaggio.
2. Identificare i componenti del mobile.
3. Raggruppare e controllare la ferramenta.
4. Utilizzare gli strumenti necessari.
5. Creare una zona per il montaggio.
6. Eseguire il montaggio.



Consigli per la manutenzione e la pulizia

- Non forzare mai i collegamenti.
- Stringere le viti dopo un certo periodo d'uso.
- Conservare il manuale di montaggio; se manca un pezzo, è il modo più semplice per contattare il negozio.
- Non utilizzare polveri abrasive, lana d'acciaio o solventi.
- Non bagnare il prodotto.
- Rimuovere delicatamente la polvere.
- Usare un panno leggermente umido.

Istruzioni per la manutenzione
Panno morbido leggermente umido
Acqua saponata
Acqua con detergente
Spugna antigraffio
Manutenzione specifica del produttore

Materiali												
Legno massiccio oliato	Legno cerato	Legno verniciato o tinto	Pannello in legno con carta decorativa	Pannelli rivestiti in melamina	Superficie laccata	Pietre	Pelle	Metallo	Plastica	Tessuto	Tessuto spalmato (PU, PVC)	Prodotto con parti elettriche

<input type="checkbox"/>	<input type="checkbox"/>	<input type="checkbox"/>	<input type="checkbox"/>	<input type="checkbox"/>	<input type="checkbox"/>	<input type="checkbox"/>	<input type="checkbox"/>	<input type="checkbox"/>	<input type="checkbox"/>	<input type="checkbox"/>	<input type="checkbox"/>	<input type="checkbox"/>
<input type="checkbox"/>	<input type="checkbox"/>	<input type="checkbox"/>	<input type="checkbox"/>	<input type="checkbox"/>	<input type="checkbox"/>	<input type="checkbox"/>	<input type="checkbox"/>	<input type="checkbox"/>	<input type="checkbox"/>	<input type="checkbox"/>	<input type="checkbox"/>	<input type="checkbox"/>
<input type="checkbox"/>	<input type="checkbox"/>	<input type="checkbox"/>	<input type="checkbox"/>	<input type="checkbox"/>	<input type="checkbox"/>	<input type="checkbox"/>	<input type="checkbox"/>	<input type="checkbox"/>	<input type="checkbox"/>	<input type="checkbox"/>	<input type="checkbox"/>	<input type="checkbox"/>
<input type="checkbox"/>	<input type="checkbox"/>	<input type="checkbox"/>	<input type="checkbox"/>	<input type="checkbox"/>	<input type="checkbox"/>	<input type="checkbox"/>	<input type="checkbox"/>	<input type="checkbox"/>	<input type="checkbox"/>	<input type="checkbox"/>	<input type="checkbox"/>	<input type="checkbox"/>
<input type="checkbox"/>	<input type="checkbox"/>	<input type="checkbox"/>	<input type="checkbox"/>	<input type="checkbox"/>	<input type="checkbox"/>	<input type="checkbox"/>	<input type="checkbox"/>	<input type="checkbox"/>	<input type="checkbox"/>	<input type="checkbox"/>	<input type="checkbox"/>	<input type="checkbox"/>

Avvertenze
Prima di ogni manutenzione, rimuovere la polvere con cura
Qualsiasi macchia deve essere pulita subito
Non usare mai prodotti abrasivi (polvere, lana d'acciaio)
Non usare solventi
Non bagnare
Non pulire con idropulitrice (prodotti da esterno)

<input type="checkbox"/>	<input type="checkbox"/>	<input type="checkbox"/>	<input type="checkbox"/>	<input type="checkbox"/>	<input type="checkbox"/>	<input type="checkbox"/>	<input type="checkbox"/>	<input type="checkbox"/>	<input type="checkbox"/>	<input type="checkbox"/>	<input type="checkbox"/>	<input type="checkbox"/>
<input type="checkbox"/>	<input type="checkbox"/>	<input type="checkbox"/>	<input type="checkbox"/>	<input type="checkbox"/>	<input type="checkbox"/>	<input type="checkbox"/>	<input type="checkbox"/>	<input type="checkbox"/>	<input type="checkbox"/>	<input type="checkbox"/>	<input type="checkbox"/>	<input type="checkbox"/>
<input type="checkbox"/>	<input type="checkbox"/>	<input type="checkbox"/>	<input type="checkbox"/>	<input type="checkbox"/>	<input type="checkbox"/>	<input type="checkbox"/>	<input type="checkbox"/>	<input type="checkbox"/>	<input type="checkbox"/>	<input type="checkbox"/>	<input type="checkbox"/>	<input type="checkbox"/>
<input type="checkbox"/>	<input type="checkbox"/>	<input type="checkbox"/>	<input type="checkbox"/>	<input type="checkbox"/>	<input type="checkbox"/>	<input type="checkbox"/>	<input type="checkbox"/>	<input type="checkbox"/>	<input type="checkbox"/>	<input type="checkbox"/>	<input type="checkbox"/>	<input type="checkbox"/>
<input type="checkbox"/>	<input type="checkbox"/>	<input type="checkbox"/>	<input type="checkbox"/>	<input type="checkbox"/>	<input type="checkbox"/>	<input type="checkbox"/>	<input type="checkbox"/>	<input type="checkbox"/>	<input type="checkbox"/>	<input type="checkbox"/>	<input type="checkbox"/>	<input type="checkbox"/>
<input type="checkbox"/>	<input type="checkbox"/>	<input type="checkbox"/>	<input type="checkbox"/>	<input type="checkbox"/>	<input type="checkbox"/>	<input type="checkbox"/>	<input type="checkbox"/>	<input type="checkbox"/>	<input type="checkbox"/>	<input type="checkbox"/>	<input type="checkbox"/>	<input type="checkbox"/>

Informazioni specifiche
Consultare le informazioni aggiuntive allegate al prodotto.

<input type="checkbox"/>	<input type="checkbox"/>	<input type="checkbox"/>	<input type="checkbox"/>	<input type="checkbox"/>	<input type="checkbox"/>	<input type="checkbox"/>	<input type="checkbox"/>	<input type="checkbox"/>	<input type="checkbox"/>	<input type="checkbox"/>	<input type="checkbox"/>	<input type="checkbox"/>
--------------------------	--------------------------	--------------------------	--------------------------	--------------------------	--------------------------	--------------------------	--------------------------	--------------------------	--------------------------	--------------------------	--------------------------	--------------------------



Conselhos de montagem

1. Leia atentamente as instruções de montagem.
2. Identifique os componentes do móvel.
3. Agrupe e verifique a ferragem.
4. Use as ferramentas necessárias.
5. Crie uma área para montagem.
6. Faça a montagem.



Conselhos de manutenção e limpeza

- Nunca force as ligações.
- Aperte os parafusos após algum tempo de uso.
- Guarde o manual de montagem; se faltar alguma peça, é a forma mais fácil de contactar a loja.
- Não use pós abrasivos, palha de aço ou solventes.
- Não molhe o produto.
- Remova cuidadosamente o pó.
- Use um pano ligeiramente húmido.

Materiais												
Madeira maciça com óleo	Madeira encerada	Madeira envernizada ou tingida	Painel de madeira com papel decorativo	Painéis revestidos com melamina	Superfície lacada	Pedras	Couro	Metal	Plástico	Têxtil	Tecido revestido (PU, PVC)	Produto com partes elétricas

Instruções de manutenção
Pano macio ligeiramente húmido
Água com sabão
Água com detergente
Espanja anti-riscos
Manutenção específica do fabricante

<input type="checkbox"/>	<input type="checkbox"/>	<input type="checkbox"/>	<input type="checkbox"/>	<input type="checkbox"/>	<input type="checkbox"/>	<input type="checkbox"/>	<input type="checkbox"/>	<input type="checkbox"/>	<input type="checkbox"/>	<input type="checkbox"/>	<input type="checkbox"/>	<input type="checkbox"/>
<input type="checkbox"/>	<input type="checkbox"/>	<input type="checkbox"/>	<input type="checkbox"/>	<input type="checkbox"/>	<input type="checkbox"/>	<input type="checkbox"/>	<input type="checkbox"/>	<input type="checkbox"/>	<input type="checkbox"/>	<input type="checkbox"/>	<input type="checkbox"/>	<input type="checkbox"/>
<input type="checkbox"/>	<input type="checkbox"/>	<input type="checkbox"/>	<input type="checkbox"/>	<input type="checkbox"/>	<input type="checkbox"/>	<input type="checkbox"/>	<input type="checkbox"/>	<input type="checkbox"/>	<input type="checkbox"/>	<input type="checkbox"/>	<input type="checkbox"/>	<input type="checkbox"/>
<input type="checkbox"/>	<input type="checkbox"/>	<input type="checkbox"/>	<input type="checkbox"/>	<input type="checkbox"/>	<input type="checkbox"/>	<input type="checkbox"/>	<input type="checkbox"/>	<input type="checkbox"/>	<input type="checkbox"/>	<input type="checkbox"/>	<input type="checkbox"/>	<input type="checkbox"/>
<input type="checkbox"/>	<input type="checkbox"/>	<input type="checkbox"/>	<input type="checkbox"/>	<input type="checkbox"/>	<input type="checkbox"/>	<input type="checkbox"/>	<input type="checkbox"/>	<input type="checkbox"/>	<input type="checkbox"/>	<input type="checkbox"/>	<input type="checkbox"/>	<input type="checkbox"/>

Advertências
Antes de qualquer manutenção, limpe cuidadosamente o pó
Qualquer mancha deve ser limpa rapidamente
Nunca use produtos abrasivos (pó, palha de aço)
Nunca use solventes
Não molhar
Não limpar com lavadora de alta pressão (produtos de exterior)

<input type="checkbox"/>	<input type="checkbox"/>	<input type="checkbox"/>	<input type="checkbox"/>	<input type="checkbox"/>	<input type="checkbox"/>	<input type="checkbox"/>	<input type="checkbox"/>	<input type="checkbox"/>	<input type="checkbox"/>	<input type="checkbox"/>	<input type="checkbox"/>	<input type="checkbox"/>
<input type="checkbox"/>	<input type="checkbox"/>	<input type="checkbox"/>	<input type="checkbox"/>	<input type="checkbox"/>	<input type="checkbox"/>	<input type="checkbox"/>	<input type="checkbox"/>	<input type="checkbox"/>	<input type="checkbox"/>	<input type="checkbox"/>	<input type="checkbox"/>	<input type="checkbox"/>
<input type="checkbox"/>	<input type="checkbox"/>	<input type="checkbox"/>	<input type="checkbox"/>	<input type="checkbox"/>	<input type="checkbox"/>	<input type="checkbox"/>	<input type="checkbox"/>	<input type="checkbox"/>	<input type="checkbox"/>	<input type="checkbox"/>	<input type="checkbox"/>	<input type="checkbox"/>
<input type="checkbox"/>	<input type="checkbox"/>	<input type="checkbox"/>	<input type="checkbox"/>	<input type="checkbox"/>	<input type="checkbox"/>	<input type="checkbox"/>	<input type="checkbox"/>	<input type="checkbox"/>	<input type="checkbox"/>	<input type="checkbox"/>	<input type="checkbox"/>	<input type="checkbox"/>
<input type="checkbox"/>	<input type="checkbox"/>	<input type="checkbox"/>	<input type="checkbox"/>	<input type="checkbox"/>	<input type="checkbox"/>	<input type="checkbox"/>	<input type="checkbox"/>	<input type="checkbox"/>	<input type="checkbox"/>	<input type="checkbox"/>	<input type="checkbox"/>	<input type="checkbox"/>
<input type="checkbox"/>	<input type="checkbox"/>	<input type="checkbox"/>	<input type="checkbox"/>	<input type="checkbox"/>	<input type="checkbox"/>	<input type="checkbox"/>	<input type="checkbox"/>	<input type="checkbox"/>	<input type="checkbox"/>	<input type="checkbox"/>	<input type="checkbox"/>	<input type="checkbox"/>

Informações específicas
Consulte as informações adicionais anexadas ao produto.

<input type="checkbox"/>	<input type="checkbox"/>	<input type="checkbox"/>	<input type="checkbox"/>	<input type="checkbox"/>	<input type="checkbox"/>	<input type="checkbox"/>	<input type="checkbox"/>	<input type="checkbox"/>	<input type="checkbox"/>	<input type="checkbox"/>	<input type="checkbox"/>	<input type="checkbox"/>
--------------------------	--------------------------	--------------------------	--------------------------	--------------------------	--------------------------	--------------------------	--------------------------	--------------------------	--------------------------	--------------------------	--------------------------	--------------------------



Montagehinweise

1. Lesen Sie die Montageanleitung sorgfältig durch.
2. Identifizieren Sie die Möbelteile.
3. Gruppieren und prüfen Sie die Beschläge.
4. Verwenden Sie das notwendige Werkzeug.
5. Richten Sie einen Montagebereich ein.
6. Führen Sie die Montage durch.



Hinweise zur Pflege und Reinigung

- Erzwingen Sie keine Verbindungen.
- Ziehen Sie die Schrauben nach einer gewissen Nutzungsdauer nach.
- Bewahren Sie die Montageanleitung auf; fehlt ein Teil, ist dies der einfachste Weg, das Geschäft zu kontaktieren.
- Verwenden Sie keine Scheuermittel, Stahlwolle oder Lösungsmittel.
- Nicht nass machen.
- Staub vorsichtig entfernen.
- Ein leicht feuchtes Tuch verwenden.

Materialien												
Massivholz geölt	Gewachstes Holz	Lackiertes oder gebeiztes Holz	Holzplatte mit Dekorpapier	Melaminbeschichtete Platten	Lackierte Oberfläche	Steine	Leder	Metal	Kunststoff	Textil	Beschichteter Stoff (PU, PVC)	Produkt mit elektrischen Teilen

Pflegehinweise
Weiches, leicht feuchtes Tuch
Seifenwasser
Wasser mit Reinigungsmittel
Kratzfreie Scheuerschwamm
Herstellerspezifische Pflege

<input type="checkbox"/>	<input type="checkbox"/>	<input type="checkbox"/>	<input type="checkbox"/>	<input type="checkbox"/>	<input type="checkbox"/>	<input type="checkbox"/>	<input type="checkbox"/>	<input type="checkbox"/>	<input type="checkbox"/>	<input type="checkbox"/>	<input type="checkbox"/>	<input type="checkbox"/>
<input type="checkbox"/>	<input type="checkbox"/>	<input type="checkbox"/>	<input type="checkbox"/>	<input type="checkbox"/>	<input type="checkbox"/>	<input type="checkbox"/>	<input type="checkbox"/>	<input type="checkbox"/>	<input type="checkbox"/>	<input type="checkbox"/>	<input type="checkbox"/>	<input type="checkbox"/>
<input type="checkbox"/>	<input type="checkbox"/>	<input type="checkbox"/>	<input type="checkbox"/>	<input type="checkbox"/>	<input type="checkbox"/>	<input type="checkbox"/>	<input type="checkbox"/>	<input type="checkbox"/>	<input type="checkbox"/>	<input type="checkbox"/>	<input type="checkbox"/>	<input type="checkbox"/>
<input type="checkbox"/>	<input type="checkbox"/>	<input type="checkbox"/>	<input type="checkbox"/>	<input type="checkbox"/>	<input type="checkbox"/>	<input type="checkbox"/>	<input type="checkbox"/>	<input type="checkbox"/>	<input type="checkbox"/>	<input type="checkbox"/>	<input type="checkbox"/>	<input type="checkbox"/>
<input type="checkbox"/>	<input type="checkbox"/>	<input type="checkbox"/>	<input type="checkbox"/>	<input type="checkbox"/>	<input type="checkbox"/>	<input type="checkbox"/>	<input type="checkbox"/>	<input type="checkbox"/>	<input type="checkbox"/>	<input type="checkbox"/>	<input type="checkbox"/>	<input type="checkbox"/>

Warnhinweise
Vor jeder Wartung Staub sorgfältig entfernen
Flecken sollten sofort entfernt werden
Keine scheuernden Produkte verwenden (Pulver, Stahlwolle)
Keine Lösungsmittel verwenden
Nicht nass machen
Nicht mit Hochdruckreiniger reinigen (für Außenprodukte)

<input type="checkbox"/>	<input type="checkbox"/>	<input type="checkbox"/>	<input type="checkbox"/>	<input type="checkbox"/>	<input type="checkbox"/>	<input type="checkbox"/>	<input type="checkbox"/>	<input type="checkbox"/>	<input type="checkbox"/>	<input type="checkbox"/>	<input type="checkbox"/>	<input type="checkbox"/>
<input type="checkbox"/>	<input type="checkbox"/>	<input type="checkbox"/>	<input type="checkbox"/>	<input type="checkbox"/>	<input type="checkbox"/>	<input type="checkbox"/>	<input type="checkbox"/>	<input type="checkbox"/>	<input type="checkbox"/>	<input type="checkbox"/>	<input type="checkbox"/>	<input type="checkbox"/>
<input type="checkbox"/>	<input type="checkbox"/>	<input type="checkbox"/>	<input type="checkbox"/>	<input type="checkbox"/>	<input type="checkbox"/>	<input type="checkbox"/>	<input type="checkbox"/>	<input type="checkbox"/>	<input type="checkbox"/>	<input type="checkbox"/>	<input type="checkbox"/>	<input type="checkbox"/>
<input type="checkbox"/>	<input type="checkbox"/>	<input type="checkbox"/>	<input type="checkbox"/>	<input type="checkbox"/>	<input type="checkbox"/>	<input type="checkbox"/>	<input type="checkbox"/>	<input type="checkbox"/>	<input type="checkbox"/>	<input type="checkbox"/>	<input type="checkbox"/>	<input type="checkbox"/>
<input type="checkbox"/>	<input type="checkbox"/>	<input type="checkbox"/>	<input type="checkbox"/>	<input type="checkbox"/>	<input type="checkbox"/>	<input type="checkbox"/>	<input type="checkbox"/>	<input type="checkbox"/>	<input type="checkbox"/>	<input type="checkbox"/>	<input type="checkbox"/>	<input type="checkbox"/>
<input type="checkbox"/>	<input type="checkbox"/>	<input type="checkbox"/>	<input type="checkbox"/>	<input type="checkbox"/>	<input type="checkbox"/>	<input type="checkbox"/>	<input type="checkbox"/>	<input type="checkbox"/>	<input type="checkbox"/>	<input type="checkbox"/>	<input type="checkbox"/>	<input type="checkbox"/>

Spezifische Informationen
Beachten Sie die dem Produkt beiliegenden zusätzlichen Informationen.

<input type="checkbox"/>	<input type="checkbox"/>	<input type="checkbox"/>	<input type="checkbox"/>	<input type="checkbox"/>	<input type="checkbox"/>	<input type="checkbox"/>	<input type="checkbox"/>	<input type="checkbox"/>	<input type="checkbox"/>	<input type="checkbox"/>	<input type="checkbox"/>	<input type="checkbox"/>
--------------------------	--------------------------	--------------------------	--------------------------	--------------------------	--------------------------	--------------------------	--------------------------	--------------------------	--------------------------	--------------------------	--------------------------	--------------------------



ES: IMPOR TANTE: RECICLAJE.

Una vez finalizado el montaje:

- Deposita la caja de cartón en el contenedor de papel y cartón.
- Deposita las piezas plásticas no reutilizables en el contenedor de plásticos y envases.
- Si no quiere conservar este folleto, deposítalo en el contenedor de papel y cartón.

EN: IMPOR TANT: RECYCLING.

Once assembly is complete:

- Place the cardboard box in the paper and cardboard recycling container.
- Place non-reusable plastic parts in the plastic and packaging recycling container.
- If you don't want to keep this leaflet, place it in the paper and cardboard recycling container.

FR: IMPOR TANT : RECYCLAGE.

Une fois le montage terminé :

- Déposez la boîte en carton dans le conteneur pour papier et carton.
- Déposez les pièces en plastique non réutilisables dans le conteneur pour plastiques et emballages.
- Si vous ne souhaitez pas conserver ce livret, déposez-le dans le conteneur pour papier et carton.

IT: IMPOR TANTE: RICICL AGGIO.

Una volta completato il montaggio:

- Smaltisci la scatola di cartone nel contenitore per carta e cartone.
- Smaltisci le parti in plastica non riutilizzabili nel contenitore per plastica e imballaggi.
- Se non desideri conservare questo libretto, gettalo nel contenitore per carta e cartone.

PT: IMPOR TANTE: RECICL AGEM.

Após concluir a montagem:

- Coloque a caixa de cartão no contentor de papel e cartão.
- Coloque as peças plásticas não reutilizáveis no contentor de plásticos e embalagens.
- Se não quiser guardar este folheto, coloque-o no contentor de papel e cartão.

DE: WICHTIG: REC YCLING.

Nach dem Zusammenbau:

- Entsorge den Karton im Papier- und Kartoncontainer.
- Nicht wiederverwendbare Kunststoffteile gehören in den Container für Kunststoffe und Verpackungen.
- Wenn du dieses Heft nicht aufbewahren möchtest, wirf es in den Papier- und Kartoncontainer.

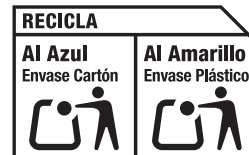

<https://quefairedemesdechets.fr>