

825606

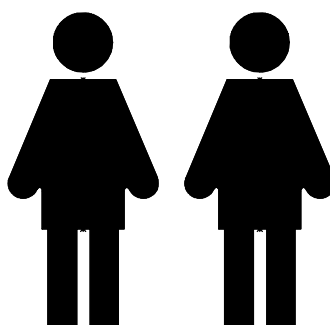
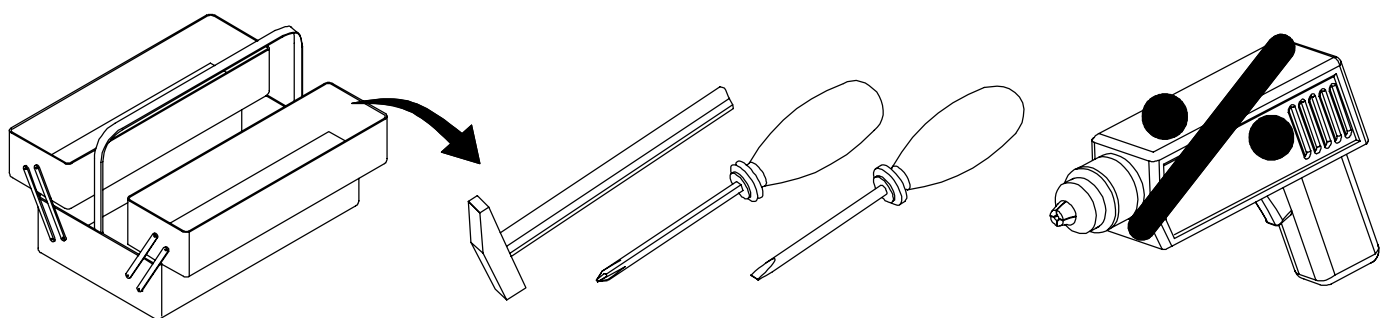
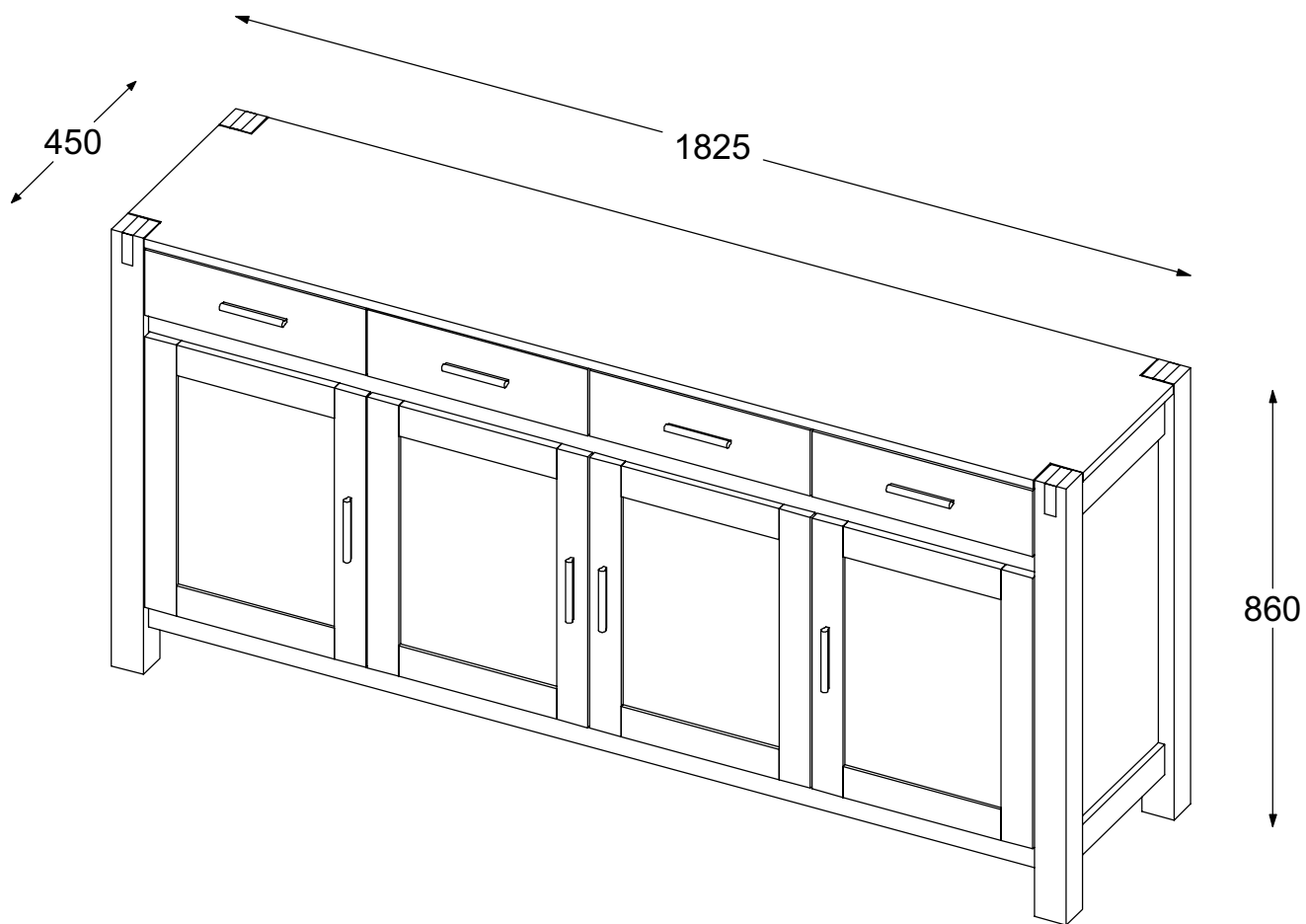

**WICHTIG - FÜR SPÄTERE VERWENDUNG
AUFBEWAHREN - SORGFÄLTIG LESEN**

**VIGTIGT - Samvejledningen skal opbevares
i arkiv til senere brug - Skal gennemlæses nøje**

**NOTICE - These instructions must be saved
for future use - Instructions must be followed**

**IMPORTANT - Veuillez conserver
la notice de montage dans le cadre
d'une prochaine utilisation.
Parcourir cette notice avec attention**

TEILCHECKLISTE
TJEKLISTE
CHECK LIST
LISTE DE CONTROLE

Ref./nr.	Art. nr.	Qty. / Stck.	Size (mm) / Måg (mm)				Qty / Stck.	✓
1	31411106	3	422	x	533	x	18	
2	31411206	1	422	x	533	x	18	
3	31411306	1	860	x	450	x	60	
4	31411406	1	860	x	450	x	60	
5	31411506	1	704	x	424	x	18	
6	31411606	1	424	x	143	x	18	
7	31436506	1	1825	x	450	x	18	
8	31436606	1	1723	x	412	x	18	
9	31436706	1	1703	x	50	x	18	
10	31436806	1	1703	x	50	x	18	
11	31412106	2	723	x	434	x	5	
12	31412206	2	723	x	423	x	5	
13	31412306	4	422	x	130	x	18	
14	31412406	4	400	x	100	x	14	
15	31412506	4	353	x	89	x	14	
16	31412606	4	402	x	365	x	5	
17	31412706	2	434	x	417	x	18	
18	31437606	1	830	x	417	x	18	
19	31412906	4	400	x	100	x	14	
20	31413006	1	512	x	32	x	8	
21	31438006	1	704	x	424	x	18	
22	31449106	1	117	x	65	x	65	

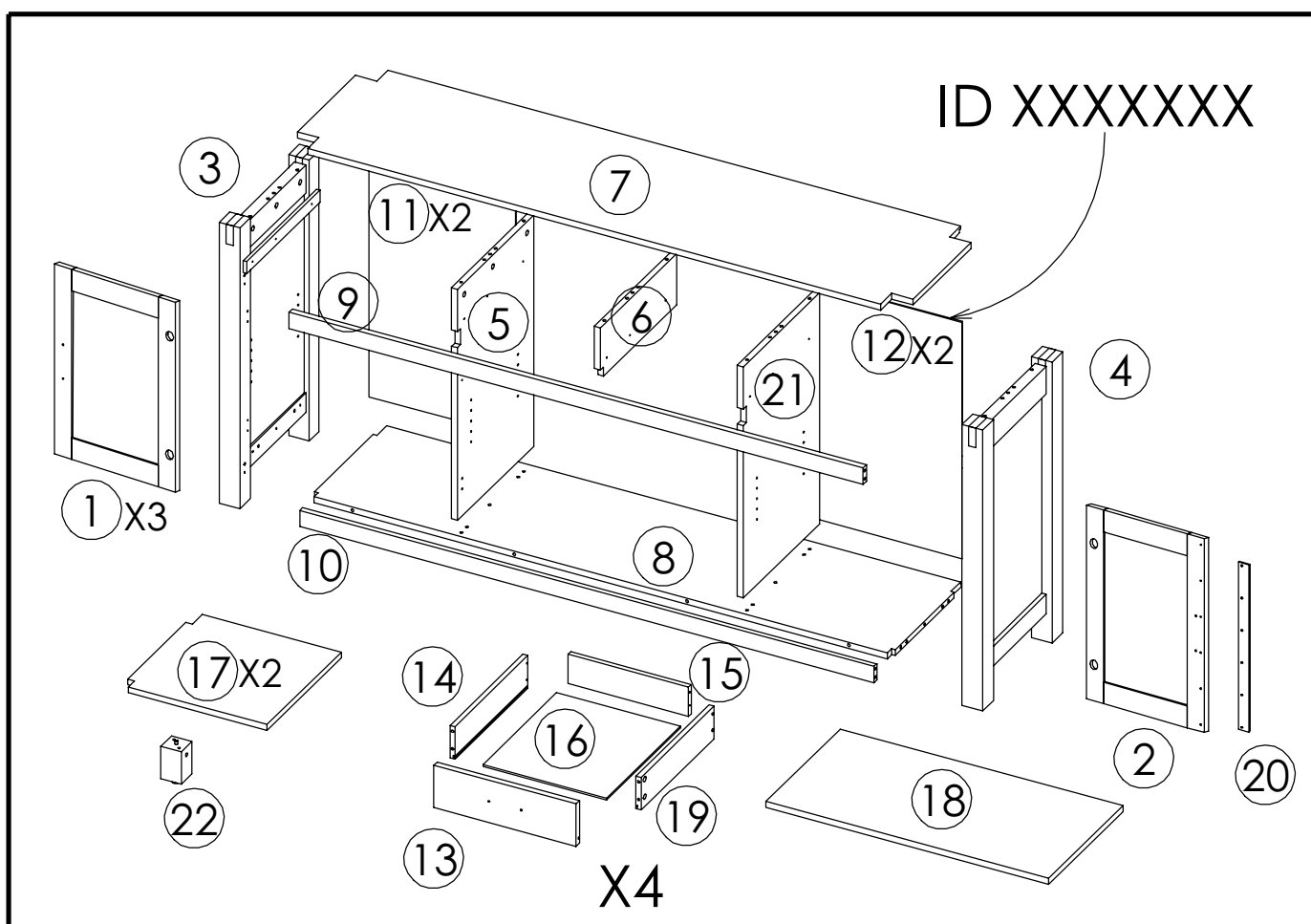

Sollten Sie eventuelle Ersatzteile oder Reklamations Teile fordern, dann bitten wir Sie, diese Seite mitschicken.

Skulle de få brug for reklamationsdele, beder vi dem medsende denne side

If you should be in the need of spareparts, please enclose this page

Si vous desirez des pieces de reserve, veuillez joindre cette page

Name/Name/navn/Nom _____

Adresse/Address/: _____

PLZ/post.nr/postal code _____

Telefon/telephone: _____

Oberfläche/behandling/Treatment/Finition: _____ Serial No. _____











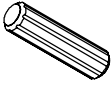
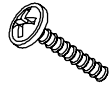
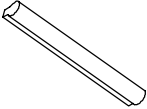
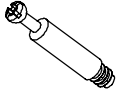

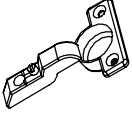
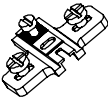

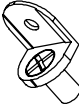

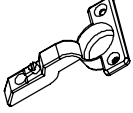
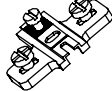

Ursache/årsag/ Reason/Motif _____

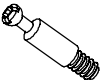
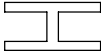

TEILCHECKLISTE - TJEKLISTE - CHECK LIST - LISTE DE CONTROLE

f	Art.:	Qty/ Stck.	✓
A	314339	22	
B	314339	16	
C	314339	8	
D	314339	29	
E	314339	29	
F	314339	4	
G	314339	4	
H	314339	84	
I	314339	12	
J	314339	4	
K	314339	4	
L	314339	6	
M	314339	4	

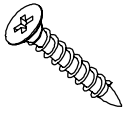
Ref./Nr.	Art.:	Qty./Stck.	✓
N	314339	4	
O	314339	16	
P	314339	84	
Q	314339	4	
R	314339	4	
S	314339	16	
T	314339	1	
U	314339	1	
V	314339	16	
W	314339	2	
X	314339	2	
Y	314339	6	

22 - A  Ø8 x 35mm	16 - B  M4 x 23mm	8 - C  120mm	29 - D  Ø6x44mm	29 - E  Ø15x12mm	4 - F 
4 - G 	84 - H  Ø3.5x12mm	12 - I 	4 - J  400mm	4 - K  400mm	6 - L  40mm
4 - M 	4 - N 	16 - O  Ø12x9mm	84 - P  20mm	4 - Q  400mm	4 - R  400mm
16 - S  Ø6x34mm	1 - T  717mm	1 - U 	16 - V  Ø4x25mm	2 - W 	2 - X  Ø4x38mm
6 - Y  Ø3x12mm					

Geehrter Kunde.
Hier haben Sie die Möglichkeit die mitgelieferten
Schrauben nachzumessen.

Kære kunde.
Her har De muligheden for at måle medsendte beslag.

Dear Customer.
Below you have the opportunity to measure the
Enclosed Hardware.

Cher Client.
La règle ci jointe vous permet de mesurer la visserie.

Name/Name/navn/Nom _____

Adresse/Address/: _____

PLZ/post.nr/postal code _____

Telefon/telephone: _____

Oberfläche/behandling/Treatment/Finition: _____

Serial No. _____

Ursache/årsag/ Reason/Motif _____

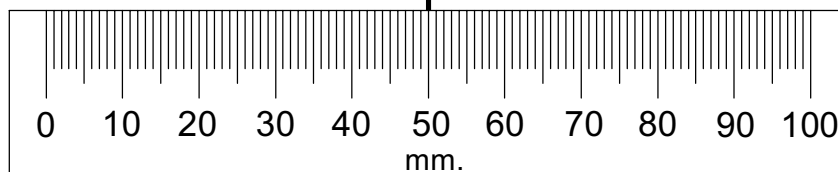

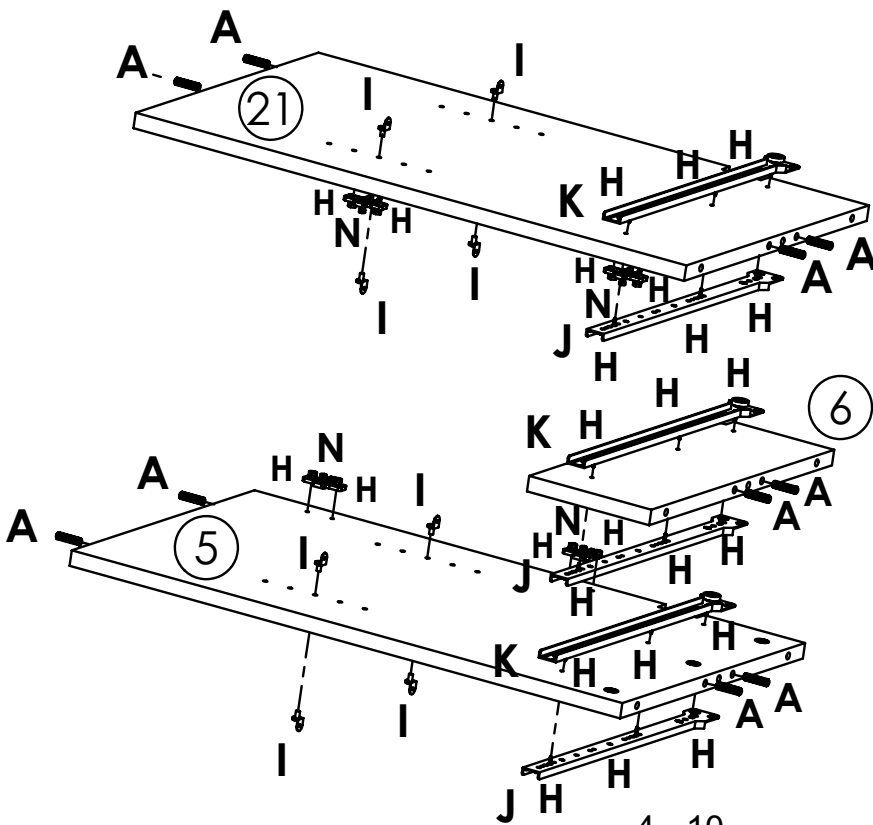
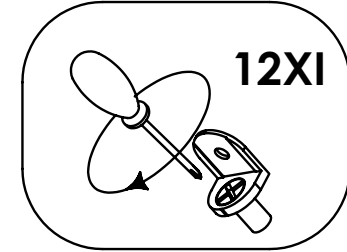
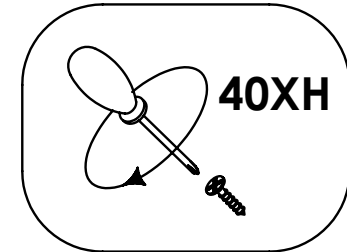
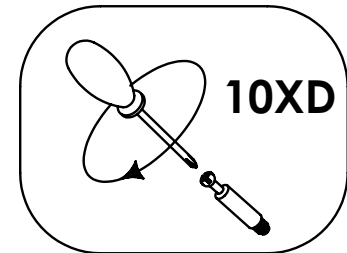
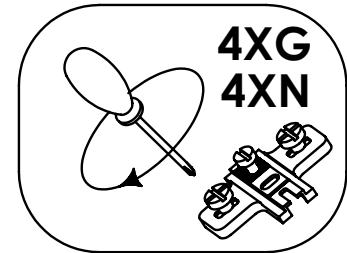
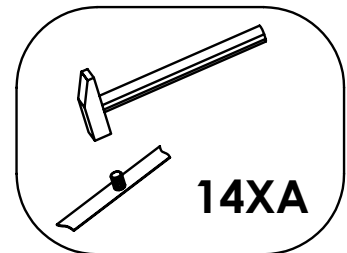
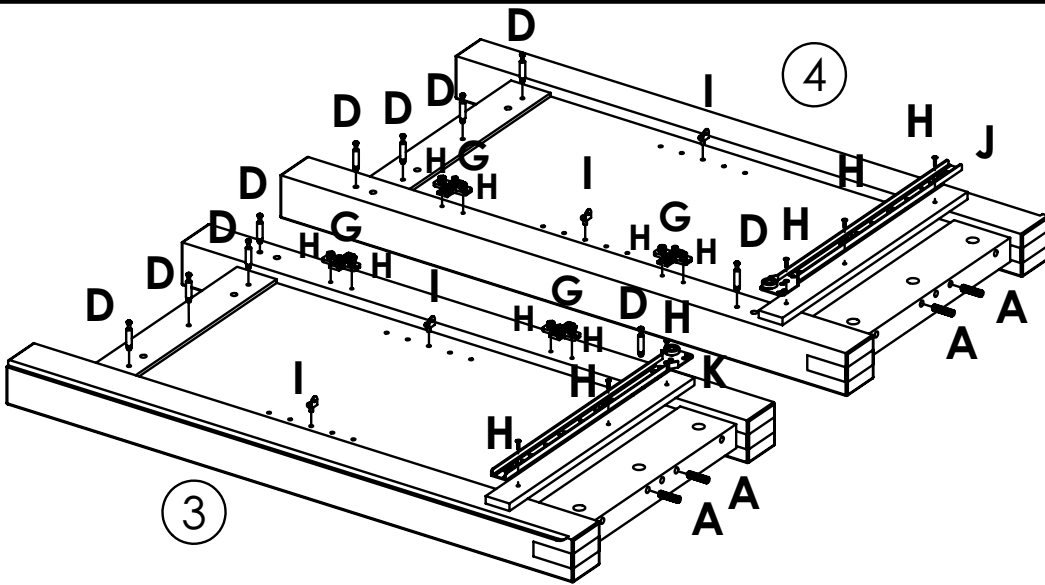
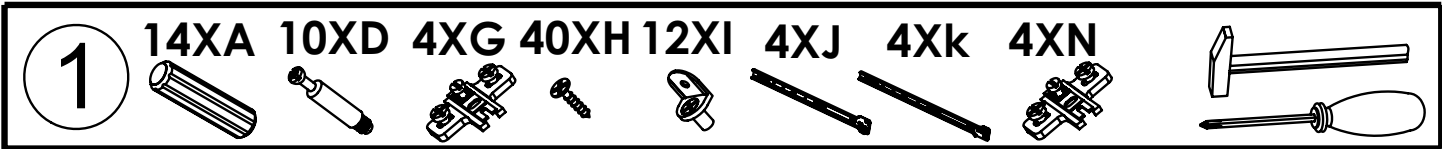
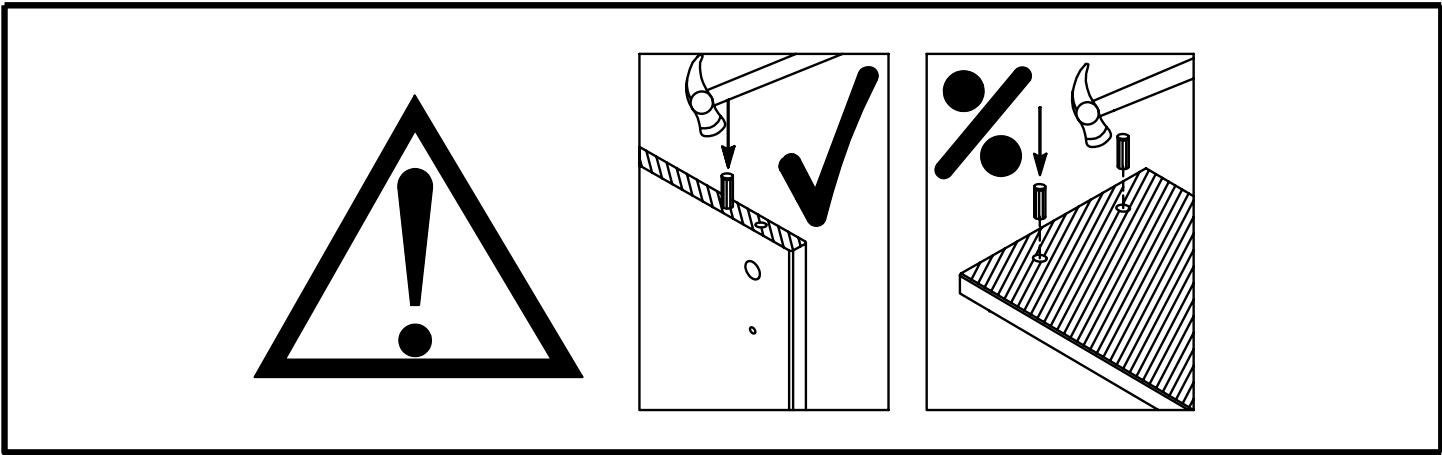

2 7XE 19XD 8XA



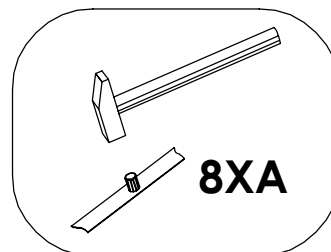
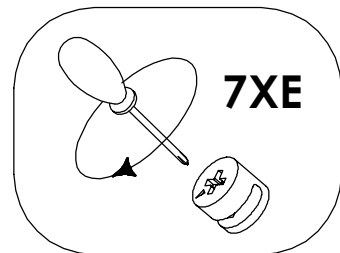
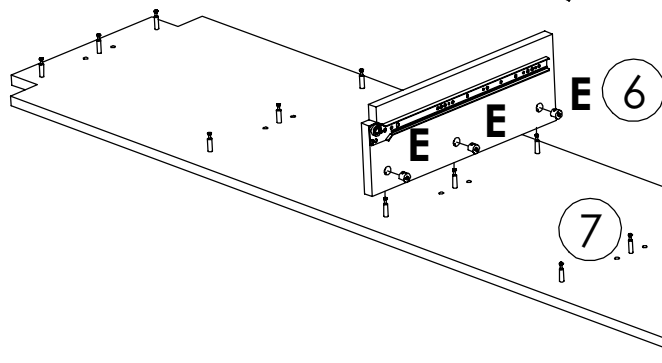
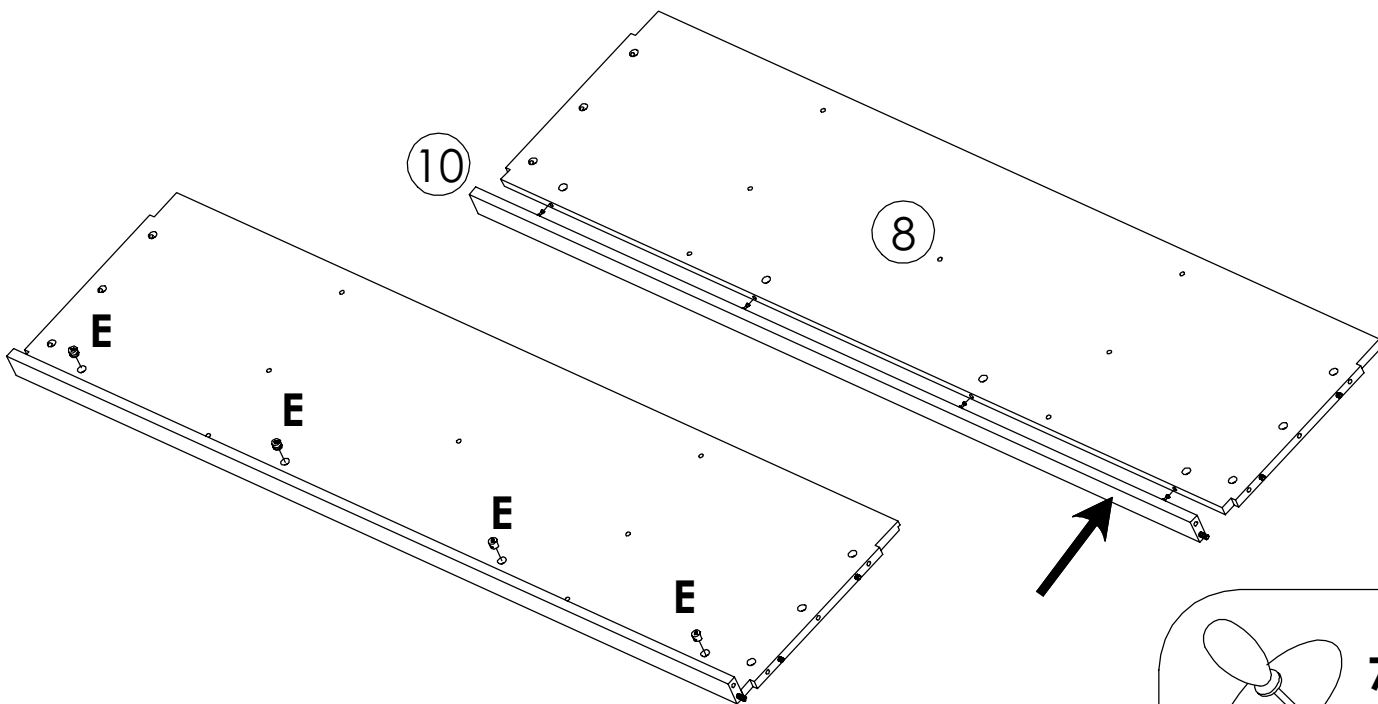
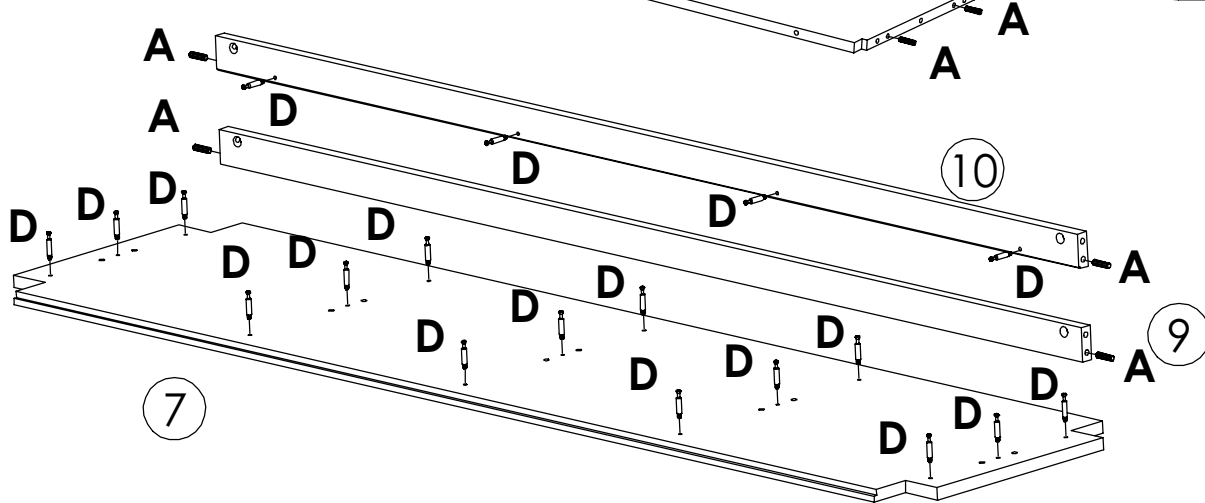
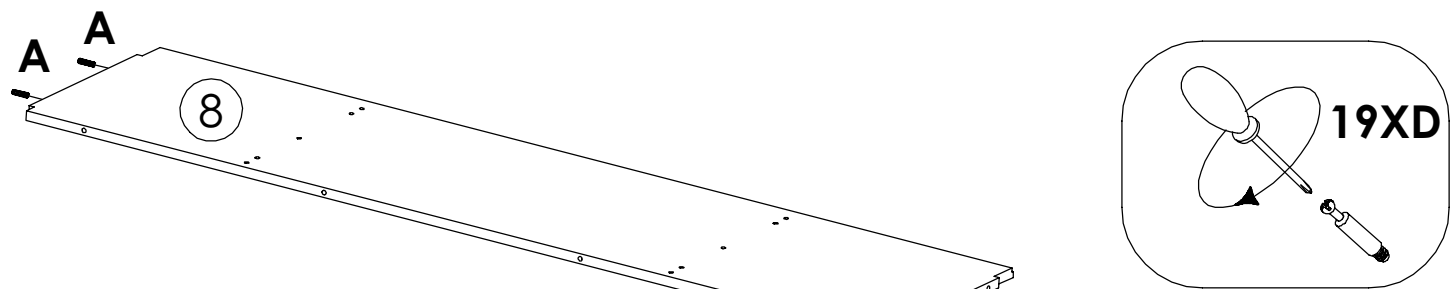

3 **6XL**  **1XU** 

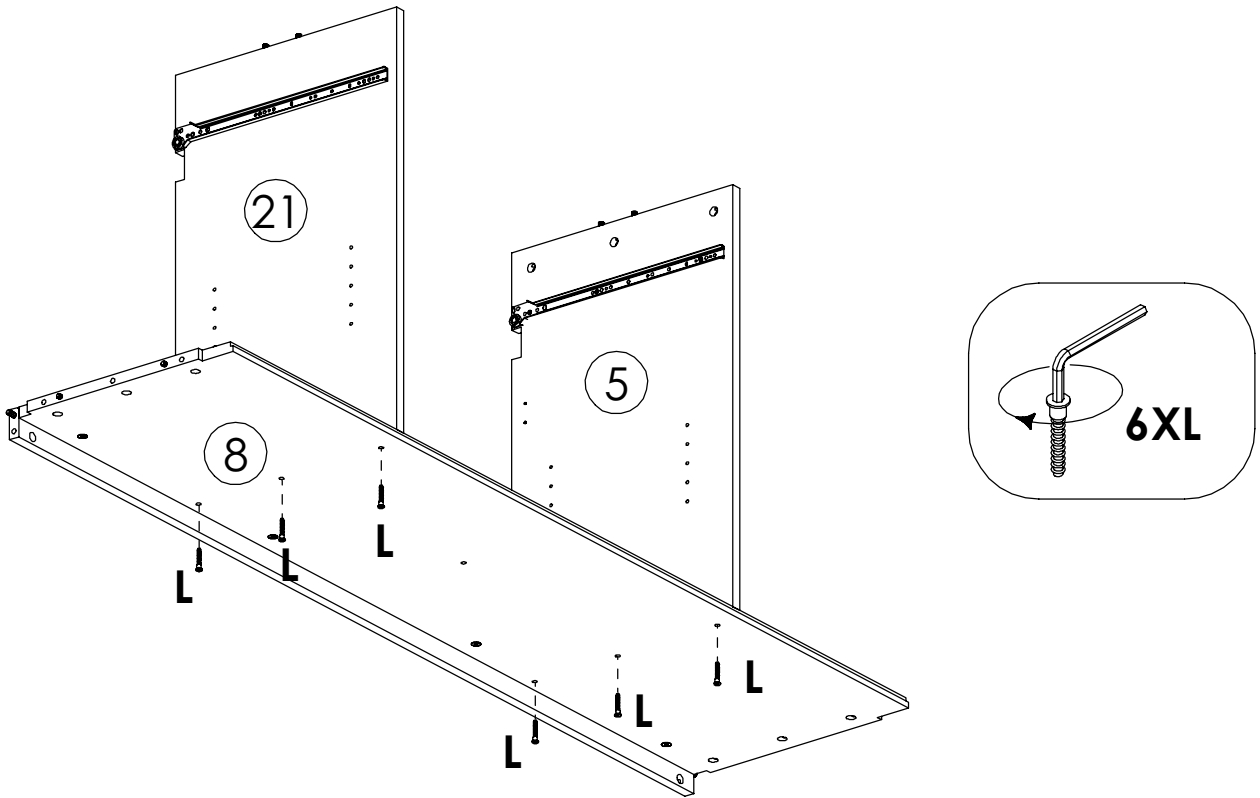

4 **10XE**  

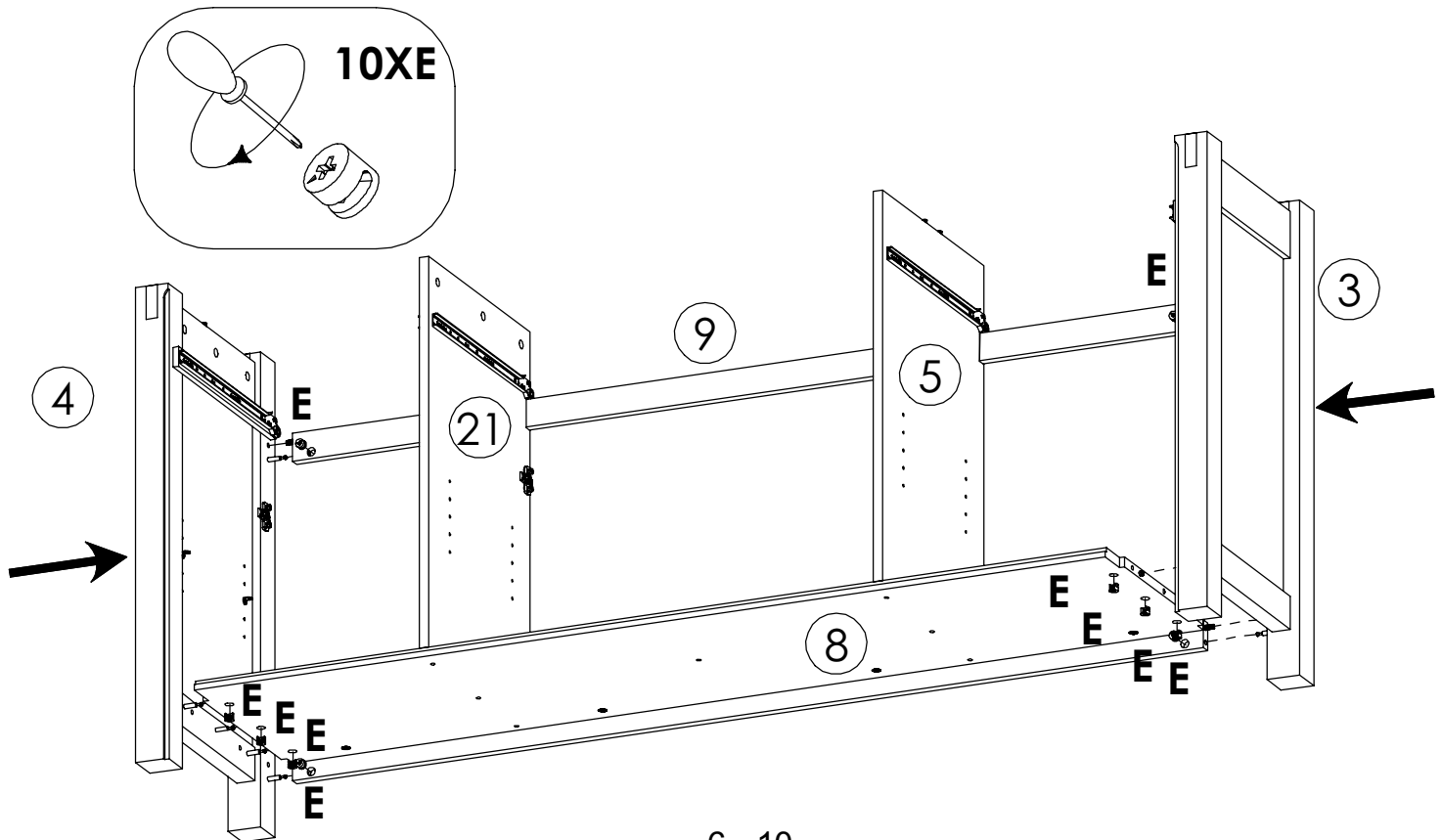

5 12XE 2XW 4XH

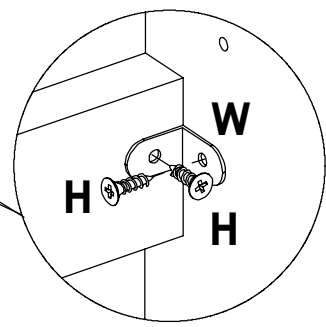
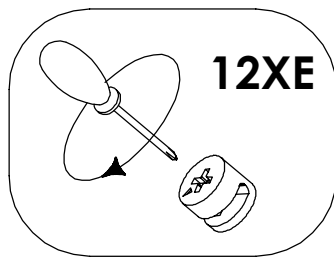
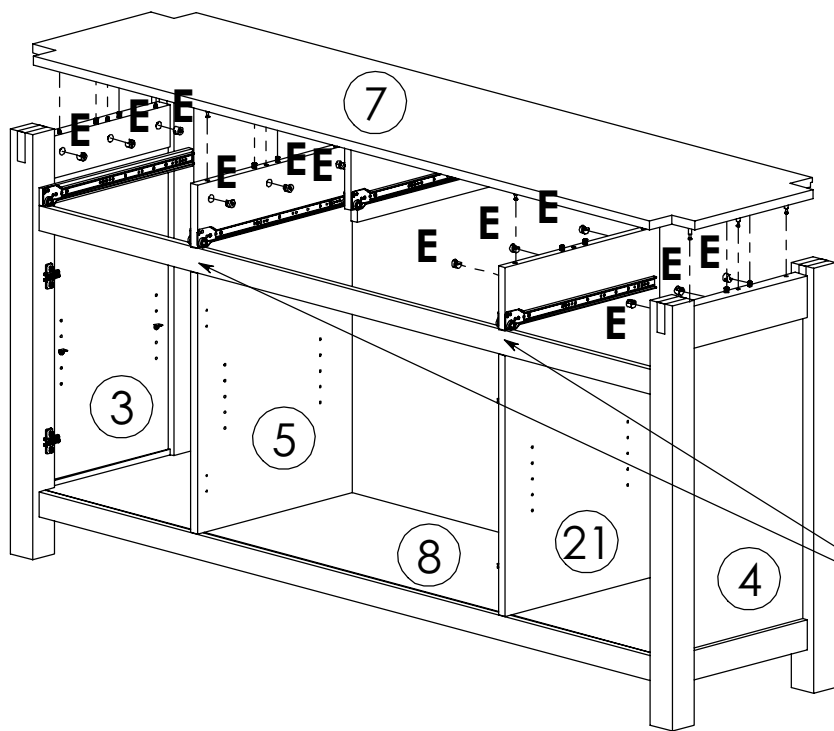

6 72xP 1xT 2xX

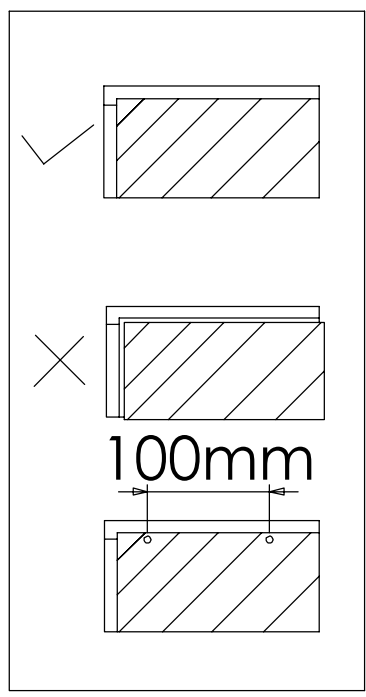
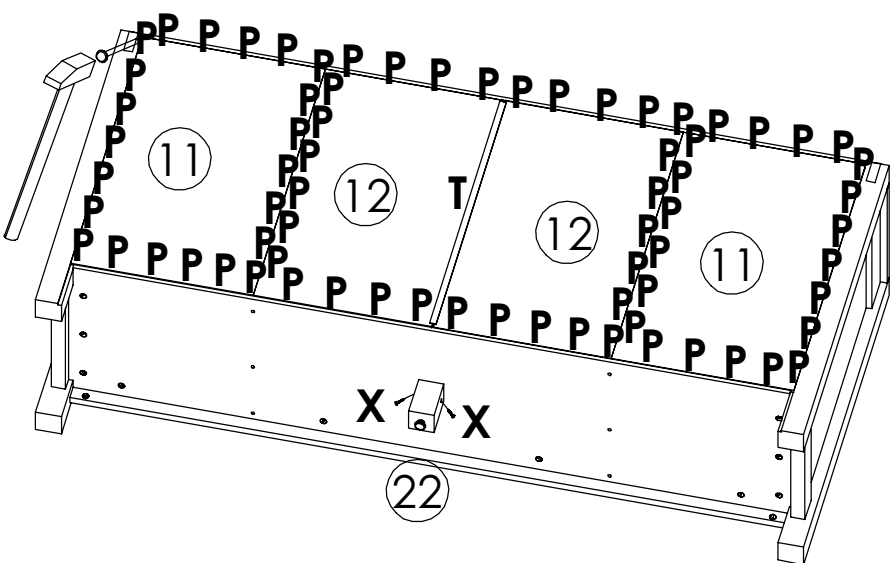

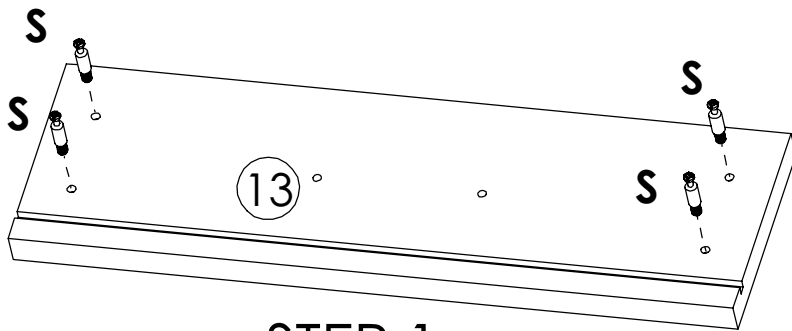
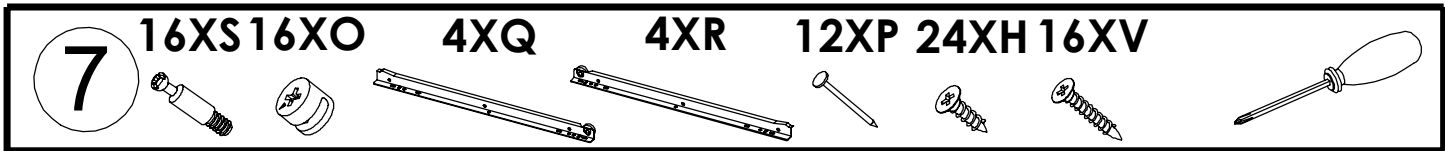

STEP 1

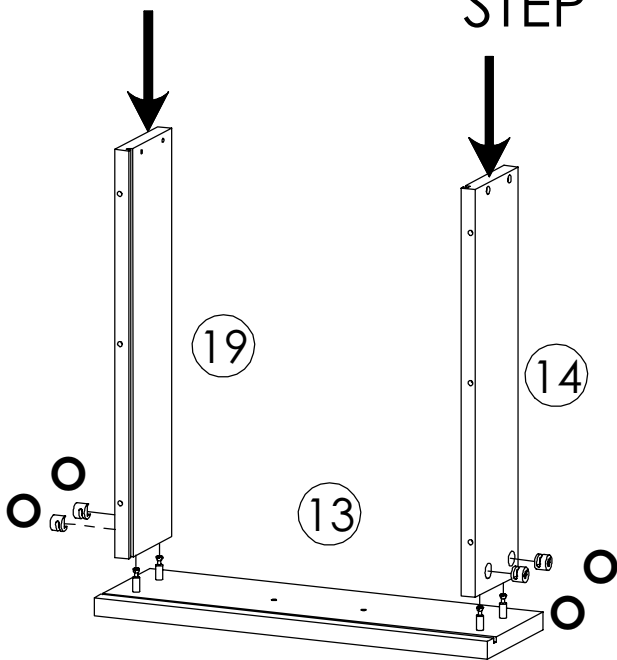
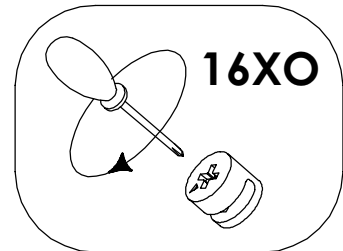

STEP 2

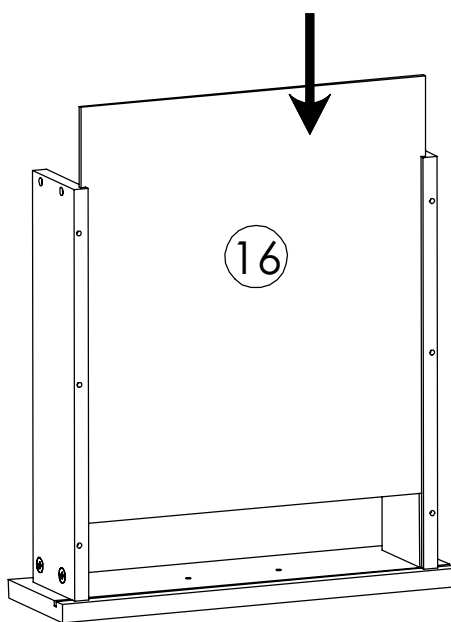
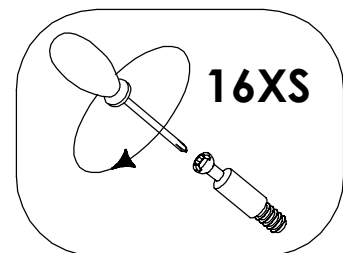

STEP 3

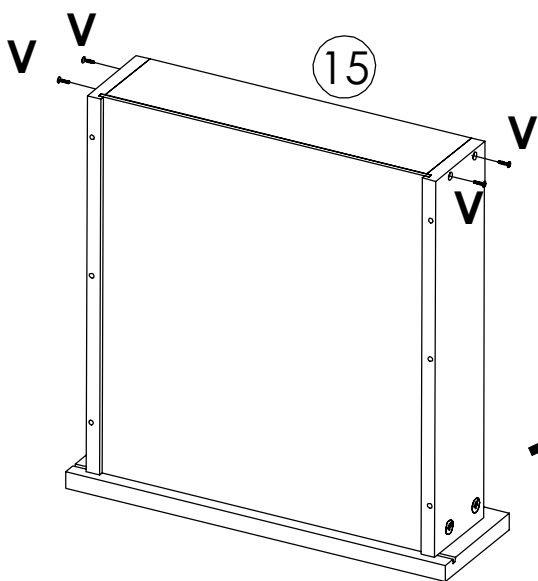
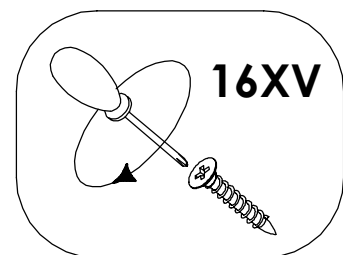

STEP 4

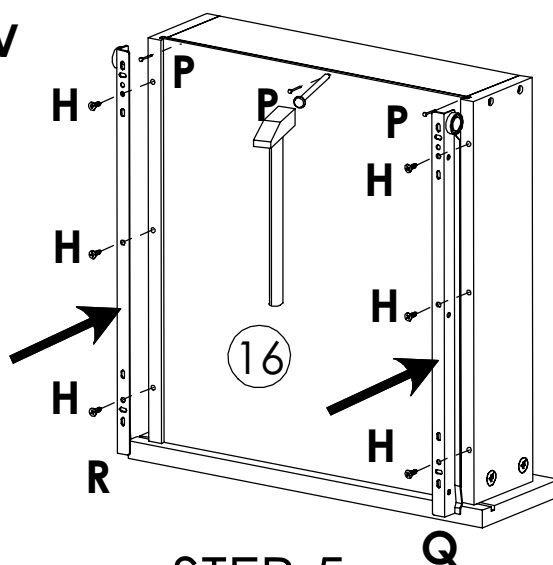
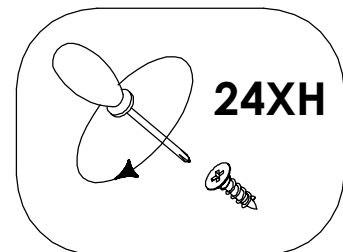

STEP 5

X4

8 8XB 4XC 

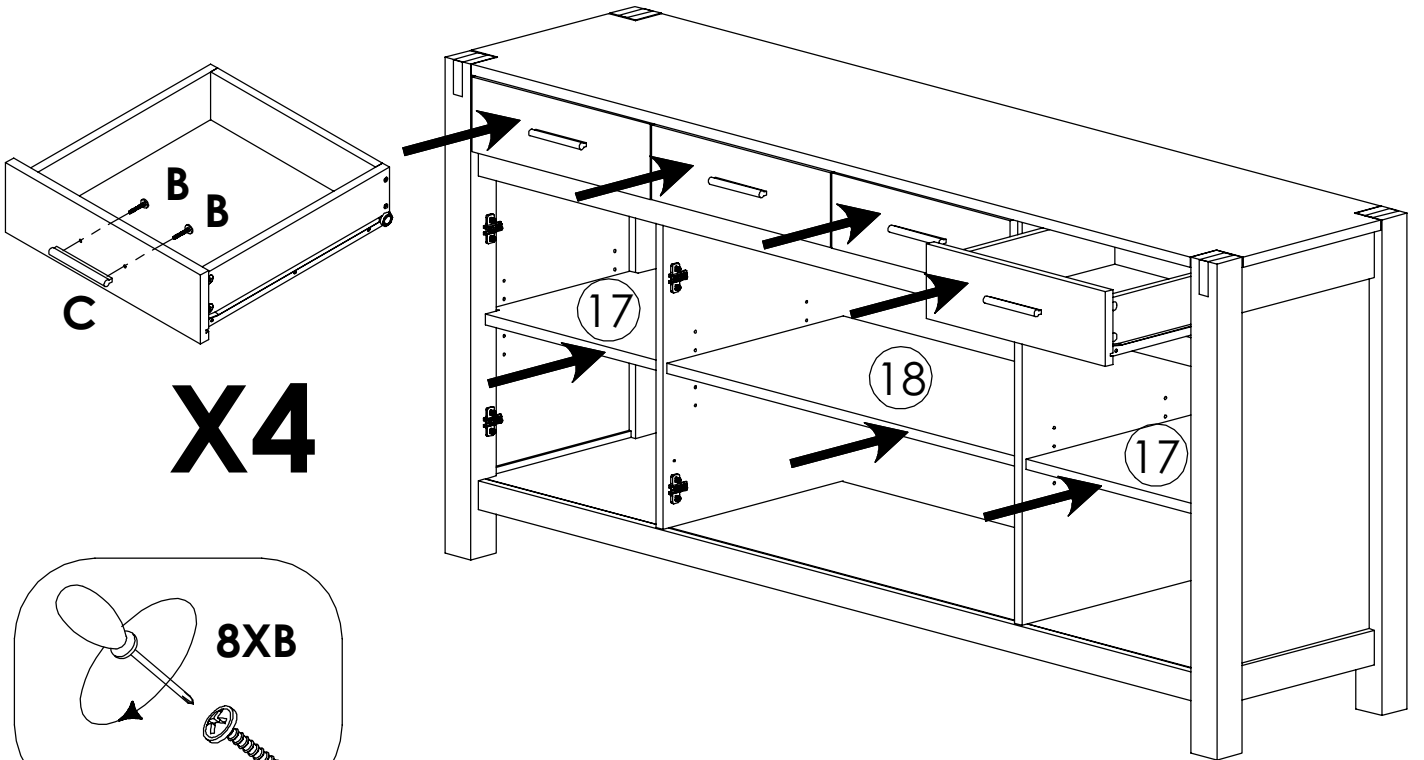

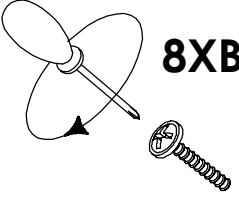
 8XB

9 4XF 4XM 16XH 8XB 4XC 6XY

Side doors

Middle door

Middle door

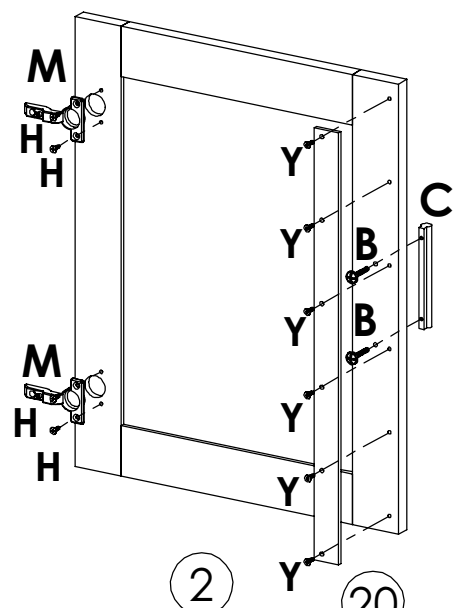
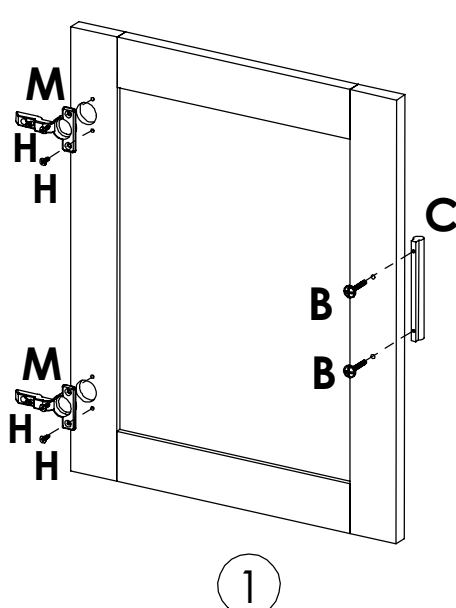
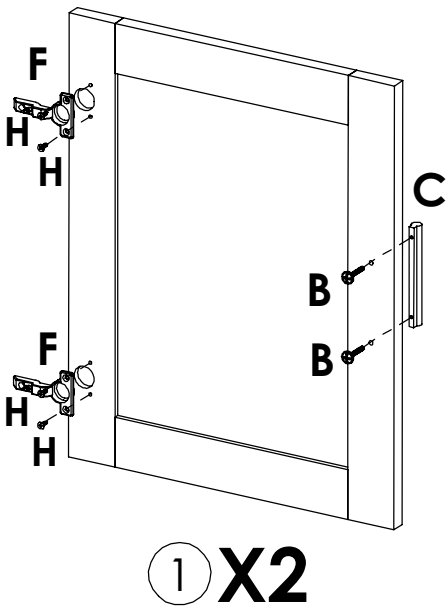

10

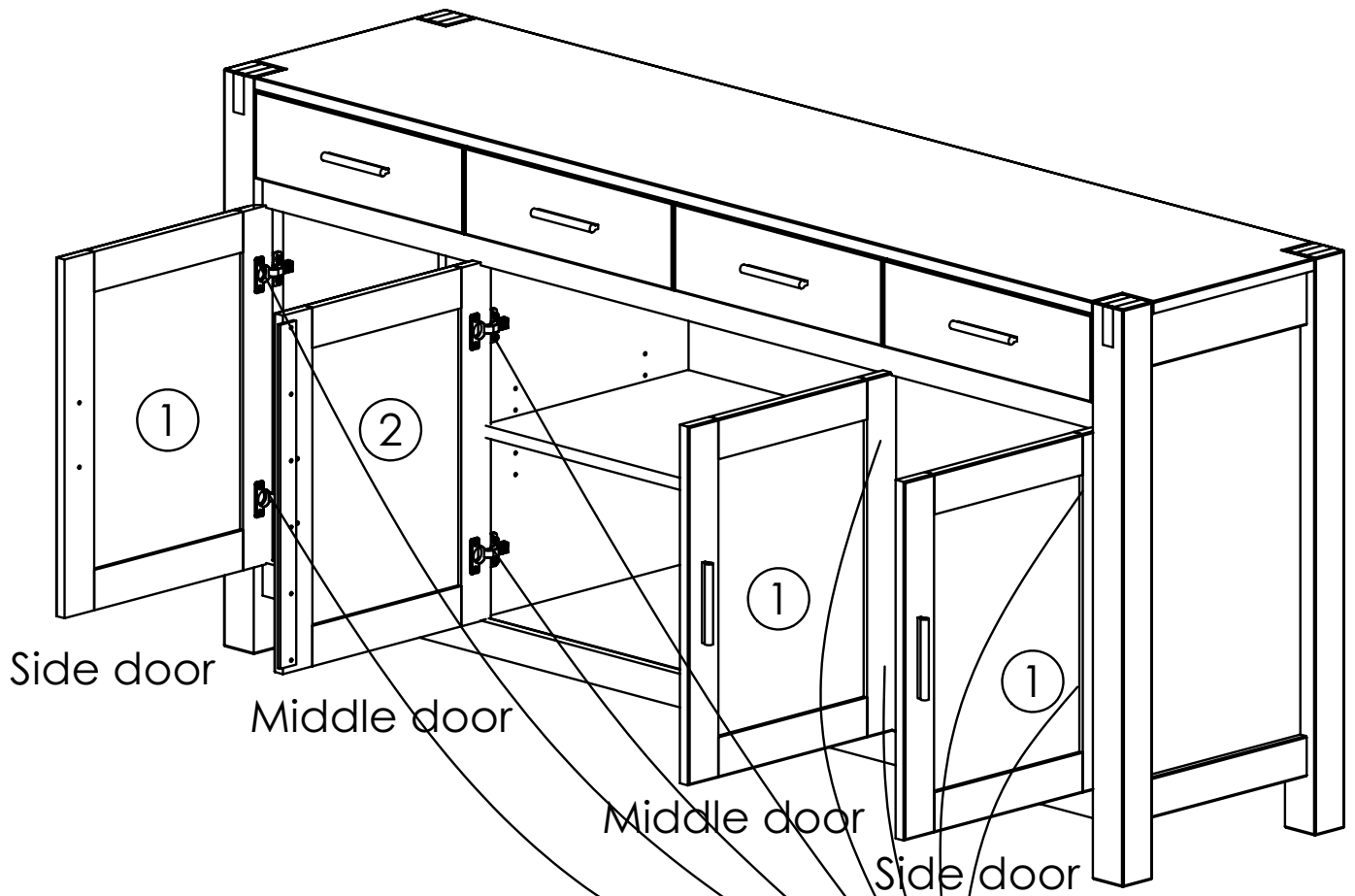
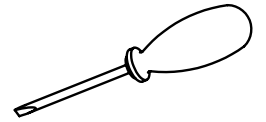

Side door

Middle door

Middle door

Side door

